

Technical data sheet

340-024-05-S2/8Fx

Spring return fire

Description

Spring- return fire Actuator including external tripping device for fire and smoke dampers of 90° angle of rotation to be used in HVAC installations.

- **Torque Motor** **5 Nm**
- **Torque Spring** **5 Nm**
- **Nominal Voltage** **24 VAC/DC**
- **Control** **2 Point**
- **Auxiliary switch** **2x fixed, not adjustable**
- **Damper coupling** **form closure 8 mm (8F 8)**
form closure 10 mm (8F10)
form closure 12 mm (8F12)



Technical data

Nominal voltage	Nominal voltage	24 VAC (50/60Hz), 24 VDC
	Nominal voltage range	19...29 VAC/DC
	Power consumption Motor (Motion)	6,5 W
	Power consumption Standby (end position)	2 W
	Wire sizing	9 VA
	Control	2 Point
	Position feedback	-
	Auxiliary switch	2 x SPDT (AgAu)
	Contact load	1 mA...5 (2,5) A, 5 VDC...250 VAC
	Switching point	5° / 80° @ -5°...+90°
	Thermal tripping device	-
	Temperature TF1	-
	Temperature TF2	-
	Connection Motor	Cable 1000 mm, 2 x 0,75 mm ² (halogen free)
	Connection Auxiliary switch	Cable 1000 mm, 6 x 0,75 mm ² (halogen free)
Connection GUAC	-	
Functional data	Torque Motor	>5 Nm
	Torque Spring	>5 Nm
	Synchronised speed	±5%
	Direction of rotation	Selected by mounting
	Manual override	Manual operation
	Angle of rotation	-5°...max.+90°
	Running time Motor	<75 s / 90°
	Running time Spring	<20 s / 90°
	Sound power level Motor	<45 dB(A)
	Sound power level Spring	<65 dB(A)
Damper coupling	form closure 8 mm (8F 8)	
	form closure 10 mm (8F10)	
	form closure 12 mm (8F12)	

Technical data

Functional data	Position indication	Mechanical with pointer
	Service life	>60.000 cycles (-5°...+90°...-5°)
Safety	Protection class	III (low voltage safety current)
	Degree of protection	IP54
	EMC	CE (2004/108/EG)
	LVD	CE (2006/95/EG)
	Mode of operation	Typ 1.AA B (EN60730-1)
	Rated impulse voltage	0,8 kV (EN60730-1)
	Control pollution degree	3 (EN60730-1)
	Ambient temperature Normal operation	-30°C...+50°C
	Ambient temperature Safety operation	-
	Storage temperature	-30°C...+50°C
	Ambient humidity	5...95% r.F., not condensing (EN 60730-1)
	Maintenance	Maintenance-free
	Dimensions/ Weight	Dimensions
Weight		ca. 1.200g

Operating mode / Properties

Operating mode

Through connecting the power supply to BU+BN (1+2), the actuator moves to position 1 while the pre-tensioned spring is wound up the same time. If the power supply is interrupted the actuator is moving back to position 0 by the spring power. The actuator is still maintaining the minimum torque at the damper spindle.

The actuator is overload-proof and requires no end switches. It automatically stops when the end stop is reached.

Direct mounting

Simple direct mounting on the damper spindle with formlock, supplied with anchoring supports to prevent the actuator from rotating.

Signaling

The two integrated auxiliary switches are activated at the fixed switching positions (< 5° and > 80°). The damper position can be checked by the mechanical pointer.

Manual override

The actuator can be operated only manually while the power supply is off. The supplied lever is to open and lock the damper position. The lock stays until the power supply is put on.

Connection / Safety remarks

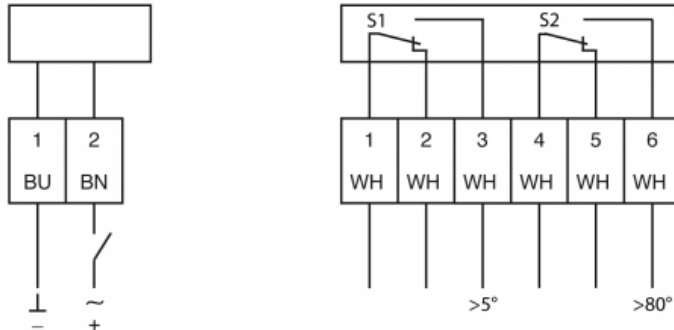
Safety remarks

- Connect via safety isolation transformer
- The actuator is not allowed to be used outside the specified field of application, especially in airplanes.
- In may only be installed by suitably trained personnel. Any legal regulations or regulations issued by authorities must be observed during assembly.
- The device may only be opened at the manufacturer's site.
- When calculating the required torque, the specifications supplied by the damper manufacturers (cross- section, design, installation site), and the air flow conditions must be observed.
- The actuator is not allowed to be disposed of as household refuse. All locally valid regulations and requirements must be observed.
- The actuator is adapted and mounted to the fire and smoke damper by the damper manufacturer. For this reason, the actuator is only supplied direct to safety damper manufacturers. The manufacturer then bears full responsibility for the proper functioning of the damper.

Technical drawing

