

## Technical data sheet

### 360-024-20-S2/8Fx

#### Spring return actuator for fire and smoke

##### Description

Spring return fire actuator including external tripping device for fire and smoke dampers of 90° angle of rotation to be used in HVAC installations

- Running time Motor 75 s / 90°
- Running time Spring 20 s / 90°
- Torque Motor 20 Nm
- Torque Spring 20 Nm
- Nominal Voltage 24 VAC/DC
- Control 2 Point
- Auxiliary switch 2x fixed, not adjustable
- Damper shaft adaption form fit 8 mm (8F 8)  
form fit 10 mm (8F10)  
form fit 12 mm (8F12)



##### Technical data

##### Electrical data

Nominal voltage	24 VAC/DC
Nominal voltage range	19...29 VAC/DC
Power consumption motor (motion)	10,5 W
Power consumption standby (end position)	2,5 W
Wire sizing	14,0 VA
Control	2 Point
Position feedback	-
Auxiliary switch	2 x SPDT (AgAu)
Contact load	1 mA...5 (2,5) A, 5 VDC...250 VAC
Switching point	5° / 80° @-5°...+90°
Thermal tripping device	-
Temperature TF1	-
Temperature TF2	-
Connection Motor	Cable 1000 mm, 2 x 0,75 mm <sup>2</sup> (halogen free)
Connection Auxiliary switch	Cable 1000 mm, 6 x 0,75 mm <sup>2</sup> (halogen free)
Connection GUAC	-

##### Functional data

Torque Motor	> 20 Nm
Torque Spring	> 20 Nm
Synchronised speed	±5%
Direction of rotation	selected by mounting
Manual override	Manual operation
Angle of rotation	-5°...max. +90°
Running time Motor	75 s / 90°
Running time Spring	< 20 s / 90°

## Technical data

### Functional data

Sound power level Motor	< 45 dB(A)
Sound power level Spring	< 65 dB(A)
Damper coupling	form fit 8 mm (8F 8) form fit 10 mm (8F10) form fit 12 mm (8F12)
Position indication	mechanical with pointer
Service life	> 60.000 cycles (-5°...+90°...-5°)

### Safety

Protection class	III (safety extra-low voltage)
Degree of protection	IP54
EMC	CE (2004/108/EG)
LVD	CE (2006/95/EG)
RoHS	CE (2011/65/EU)
Mode of operation	Typ 1.AA B (EN60730-1)
Rated impulse voltage	0,8 kV (EN60730-1)
Control pollution degree	3 (EN60730-1)
Ambient temperature normal operation	-30°C...+50°C
Ambient temperature safety operation	-
Storage temperature	-30°C...+50°C
Ambient humidity	5...95% r.H., non condensing (EN 60730-1)
Maintenance	maintenance-free

### Dimensions/ Weight

Dimensions	193 x 96 x 70 mm
Weight	2400 g

## Operating mode / Properties

### Operating mode

Through connecting the power supply to BU+BN (1+2), the actuator move to position 1 while the pre-tensioned spring is wound up the same time. If the power supply is interrupted the actuator is moving back to position 0 by the spring power. The actuator is still maintaining the minimum torque at the damper spindle.

The actuator is overload-proof, requires no limit switches and automatically stops when the end stop is reached.

### Signaling

The two integrated auxiliary swithes are activated at he fixed switching positions (<5° and >80°). The damper position can be checked by the mechanical pointer.

### Direct mounting

Simple direct mounting on the damper spindle with formlock, supplied with anchoring supports to prevent the actuator from rotating.

### Manual operation

The actuator can be operated only manually while the power supply is off. The supplied lever is to open and lock the damper position. The lock stays until the power supply is put on.

## Connection / Safety remarks

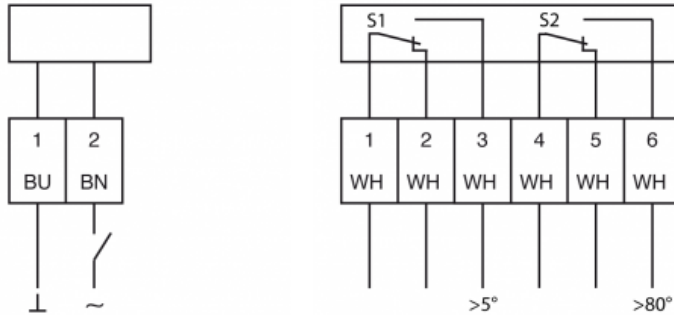
**Safety remarks**

- Connect via safety isolation transformer
- The actuator is not allowed to be used outside the specified field of application, especially in airplanes.
- It may only be installed by suitably trained personnel. Any legal regulations or regulations issued by authorities must be observed during assembly.
- The device may only be opened at the manufacturer's site.
- When calculating the required torque, the specifications supplied by the damper manufacturers (cross-section, design, installation site), and the air flow conditions must be observed.
- The actuator is not allowed to be disposed of as household refuse. All locally valid regulations and requirements must be observed.
- The actuator is adapted and mounted to the fire and smoke damper by the damper manufacturer. For this reason, the actuator is only supplied direct to safety damper manufacturer. the manufacturer then bears full responsibility for the proper functioning of the damper.

Technical drawing

