

TH300.31
Touch Button TH300 Trench Heater



For 2-pipe and 4-pipe Trench Heater Units

Features

- Manual or automatic fan control with selectable stages
- On/Off control heating/cooling valves
- Auto, Heat, Cool, and Ventilation modes
- Manual or automatic heating/cooling changeover
- Universal input for external sensor or windows/energy saving contact etc.
- Automatic heating/cooling changeover via changeover sensor
- Hot start function
- User setpoint limitation
- Clock and time schedule functions
- Key lock
- Configurable user parameters
- Modbus RTU communication
- Modern styling and capacitive touch buttons
- White backlight LCD
- Different colour options; black and white
- EU box flush-mount



Applications

TH300 Series Trench Heater Controller used in individual rooms or zones in buildings. It is designed for two and four-pipe trench heater units. TH300 has one universal input that can be used as an external sensor or open/close contact input, two analog outputs, three relay outputs, and one RS-485 port. It controls the trench heater unit depending on the internal room sensor or external return sensor temperature.

Notes on Usage

Please, read this datasheet carefully. TH300.31 controller is designed and manufactured in accordance with the latest technological developments and safety rules. To avoid injury and property damage, safety warnings must be observed.

Safety Advice-Caution

Assembly, maintenance, diagnostic, and repair must be done by authorized service. The power supply of the device is 24 V AC/DC, and it has no internal fuse. External protection with max C type 5 A circuit breaker is required in all cases. Disconnect from the power supply before separating the front plate.



Ordering Information

Product Code	Description	Power	Communication
TH300.31	2 x Analog Output (0-10 V) (1 x Fan Control, 1 x Reserved) 3 Digital Outputs (Relay) (2 x Valve Controls, 1 Reserved)	24 V AC/DC	Modbus RTU
TH300.32	1x Universal Input 1x RS-485 Port		BACnet MS/TP

Technical Specification

Power Supply	24V AC/DC 50/60 Hz
Power Consumption	Max ~3.0 VA
Electrical Connection	Terminal Connectors
Battery for Real Time Clock (RTC)	Lithium CR1220 3.3V
Measuring Range	-10°C ... +100°C (+14°F ... +212°F)
Resolution	0.1°C (1°F)
Inputs	1 x Universal Input (NTC 10K or Dry Contact)
Outputs	2 x Analog Output (0-10 V) 3 x Digital Outputs (3 X 5 (2) A Relay)
Communication	1 x RS-485 Port
Temperature Setting	5°C ... 40°C (Adjustable) (41°F ... 104°F (Adjustable))
Dimensions	86 x 86 x 52 mm
Mounting	Flush Mounted (Standard EU box)

Mounting Location

Controller is suggested to be installed indoors, a place around 1.5-meter height above the floor which represents the average room temperature. It should be away from direct sunlight, any cover, or any heat source, to avoid false signals for temperature control.



CAUTION: Cut off the power supply at circuit breaker or fuse before installation to avoid fire, shock, or death!

Mounting Instructions

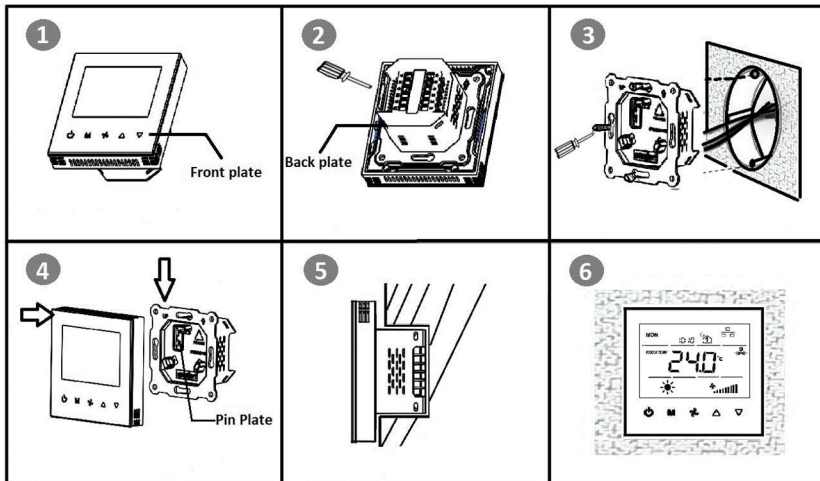

Please follow the below instructions during mounting.

Step 1: Take the controller out of the package. Get the datasheet inside the package.

Step 2: Connect the wires properly according to the wiring diagram below.

Step 3: Separate the front and back plate, and then use a screwdriver to fix the back plate into the electric box with 4 screws.

Step 4: Attach the front plate to the back plate, making sure the pin plates on each side are well matched.

Step 5: Compare it with the pictures after installation.

Step 6: Power on the controller to work.

Important Note 1: It is recommended to use the following flush mount boxes for better mounting:

Alternative 1: Manufacturer: Viko by Panasonic, Part Number: 90926006 (Depth must be minimum 50 mm!)

Alternative 2: Manufacturer: Legrand, Part Number: 0 801 21 (Depth must be minimum 50 mm!)

Important Note 2: It is recommended to use the screws included in the product box. Otherwise, there could be fitting problems during the mounting.

Connection Diagram

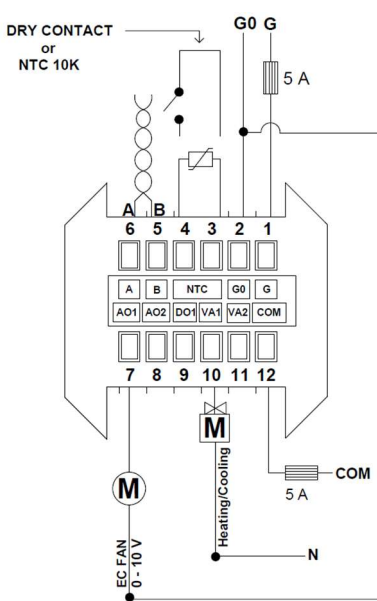

Connection Diagram for 2-Pipe Trench Heater

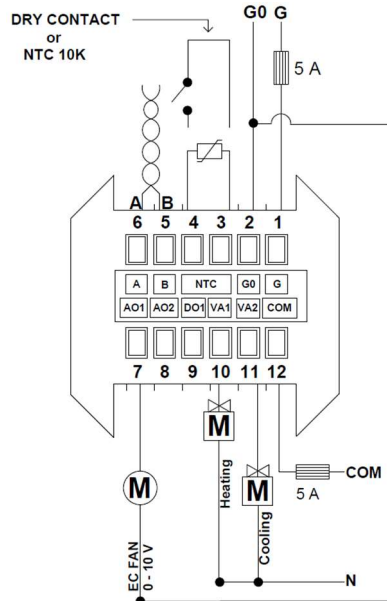

Connection Diagram for 4-Pipe Trench Heater

Note: Controller has no internal fuse. External protection with max C type 5 A circuit breaker is required in all cases. Do not confuse power cables G-G0 with Modbus communication cables A-B.

Display and Operations

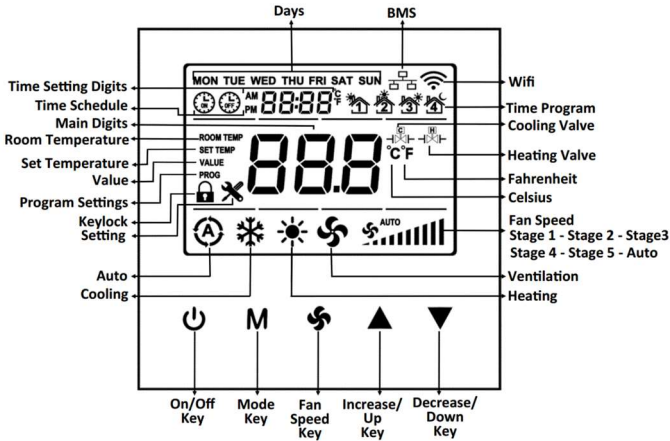

- **Mode Selection:** When the “M” key is pressed, the mode change for 2-Pipe Systems is in the form of Cooling, Heating, and Ventilation; Auto, Cooling, Heating, and Ventilation for 4-Pipe Systems.

Note: In 2-Pipe Systems, cooling mode can be turned off via P28.

- **Fan Selection:** When the “fan” key is pressed, fan speed can be selected as Stage 1, Stage 2, Stage 3, Stage 4, Stage 5, Auto. The fan can be selected as 1 stage, 3 stages, or 5 stages via parameter P42.

- **Time Setting:** After pressing the “M” key for 3 seconds, year digits flash on the panel. While the year digit flashes, if “M” key is pressed once again, the month digit starts to flash on the panel. While the month digit flashes, if “M” key is pressed once again, day digit starts to flash on the panel. While day digit flashes, if “M” key is pressed once again, the hour digit starts to flash on the panel. While the hour digit flashes, if “M” key is pressed once again, minute digit starts to flash on the panel. While minute digit flashes, if “M” key is pressed once again, day of week digit starts to flash on the panel. Year, month, day, hour, minute, and day of week can be changed by “▲” and “▼” keys.

Order: Year -> Month -> Day -> Hour -> Minute -> Day Of Week

- **Schedule Operations:** Be sure to set the time settings, before making schedule operations. After setting the day, to enter the Schedule menu, press the “M” key one time. While in the Schedule menu, “Monday opening time hour digit” flashes on the panel. When the “M” key is pressed once again, “Monday opening time minute digit” flashes on the panel. Then, when the “M” key is pressed one more time, “Monday closing time hour digit” flashes on the panel. After that when the “M” key is pressed once again, “Monday closing time minute digit” flashes on the panel. While the digits are flashing, hour and minute can be changed by “▲” and “▼” keys. Press the “M” key (one or more times) to select the other day of week.

If the weekly time program is to be set via BMS, the value of the “Weekly Time Setting Local/BMS” point should be set to 1, then the weekly time should be set. The weekly time adjustments should be completed and the value of the “Weekly Time Adjustment Local/BMS” point should be set to 0 again.

- **Key Lock Operation:** When pressing “M” and “▲” keys, the key lock digit is displayed on the panel. The panel will be locked. When the panel is locked, press the “M” and “▲” keys to unlock the panel. “Key Lock” options can be changed via parameter P6. To lock two or more buttons at the same time; sum the numbers of the buttons. To lock the mode key and on/off key, 1 (on/off) and 2 (mode) should be added and 3 should be written. To lock setpoint and fan speed, 4 (setpoint) and 8 (fan speed) should be added and 12 should be written.

Configuration

Configuration Menu Description<

When the device is on or off position, press “Main Parameter Increase Key” (M) and “Value Decrease Key” (▼) at the same time for 3 seconds, to enter the Configuration Menu. In the password screen, Password digits can be changed by “Main Parameter Increase Key” (M), Password value can be changed by “Value Increase Key” (▲) and “Value Decrease Key” (▼). Password must be entered as “203” and “Main Parameter Decrease Key”(↻) must be pressed to confirm. When the correct password is written, the configuration menu will be entered. If the wrong password is entered, “FAIL” will be written on the display, and the password will be reset. If there is no operation on the password screen for 10 seconds, the password screen will be closed. If there is no operation in the configuration menu for 30 seconds, the configuration menu will be closed. All parameters are stored within device memory ensuring no data loss in case the Controller is powered off.

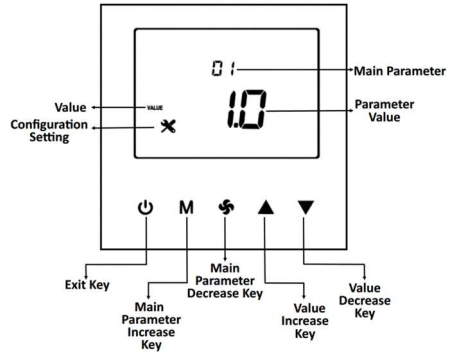

Universal Input (Parameter P32 or via Modbus)

- External Sensor for room temperature (parameter P32 = 1)

The device operates according to the external temperature sensor value read from universal input.

- External Sensor (parameter P32 = 2)

The device operates according to the internal temperature sensor value. The temperature read from the universal input can be monitored from P36 and related BMS point.

- Changeover sensor (parameter P32 = 3)

If the “Universal Input” value is selected as changeover, “dead zone” cannot be used.

Changeover sensor is only valid when “Trench Heater Type” is set to 2.

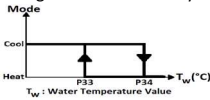

When the water temperature is above P34 the controller changes over to heating mode. It stays in heating mode until the temperature falls below P33.

When the water temperature is below P33, the controller changes over to cooling mode. It stays in cooling mode until the temperature rises above P34.

- Windows contact/Energy saving-On/Off (NC Contact) (parameter P32 = 4)

When this contact is closed, the device is in the "ON" position. When this condition is not met, the device shows “OPEN” on the panel and the outputs of the device are passive.

- Windows contact/Energy saving-Off/On (NO Contact) (parameter P32 = 5)

When this contact is opened, the device is in the "ON" position. When this condition is not met, the device shows “OPEN” on the panel and the outputs of the device are passive.

-Convector Battery Sensor (parameter P32 = 6)

The device works according to the internal temperature sensor. The fans operate in line with the hot start function.

Hysteresis (Parameter P40 or via Modbus)

The output diagram of the valve according to the relation between T_S and T_R is given below.

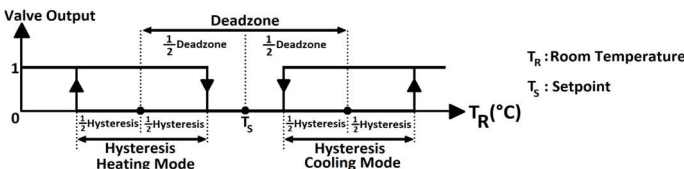

Fan/Valve Control Selection (Parameter P41 or via Modbus)

In valve independent mode, the fan operates according to manual fan selection or automatic fan control. When the valve is closed, the fan will go on to operate.

In valve-dependent mode, the fan will be closed when the valve is closed. If the valve is open, the fan will operate according to manual fan selection or automatic fan control.

Fan Stage Selection (Parameter P42 or via Modbus)

The controller fan speed can be adjusted as 1, 3, or 5 stages via P42 or via Modbus. The minimum and maximum fan speed output values can be adjusted via P43 and P44, respectively.

Fan Output Value Calculation (via Modbus)

Fan output value is calculated as below;

Fan Output Value in Fan Stage X = Fan Minimum Stage Value + Value * Fan Stage X

Value is calculated below;

Value = (Fan Maximum Stage Value – Fan Minimum Stage Value) / Fan Stage Selection

For Example;

Fan Minimum Stage Value (Parameter P43 or via Modbus) = 20

Fan Maximum Stage Value (Parameter P44 or via Modbus) = 80

Fan Stage Selection (Parameter P42 or via Modbus) = 3

Value = (80 - 20) / 3 = 20

Fan Output Value in Fan Stage 1 = 20 + 20 * 1 = 40

Fan Output Value in Fan Stage 2 = 20 + 20 * 2 = 60

Fan Output Value in Fan Stage 3 = 20 + 20 * 3 = 80

Hot Start Function

When the device is in heating mode, if the temperature of the battery that is measured with the trench heater battery sensor is below the set value (P29 - Default value is 30°C) the fan output is not active. Thus, fan operation without hot water is prevented. For the function to be active, the value of parameter P32 must be set to 6 (Trench Heater Battery Sensor). The function is not active if the sensor is not connected. The set value can be changed via P29.

Restore Factory Setting (Parameter P50 or via Modbus)

The device can load the factory setting parameters via parameter P50, by changing the value to "1", and pressing the button "Exit Key" (⏻). The display shows the top and bottom lines loaded step by step during reload process for approximately 3 seconds.

Alarms

Alarm code will appear on the screen, during an alarm. If there is more than one alarm, alarms are shown alternately.

- Onboard Sensor Alarm

If the internal temperature sensor fails, "AL 01" will appear on the screen, and "Err" will be shown on the main digits.

During the alarm, device outputs will be closed. If the "Universal Input" is selected to "External Sensor", the device continues normal operation.

- External Sensor Alarm

If the "Universal Input" parameter is set to "External Temperature Sensor" and the sensor is not connected or disconnected, "AL 02" will appear on the screen, and "Err" will be shown on the main digits. During the alarm, device outputs will be closed. "Universal Input" is set to "Not Used" to eliminate the alarm.

- Changeover Sensor Alarm

If the "Universal Input" is selected to "Changeover Sensor" also the sensor is not connected or disconnected, "AL03" is displayed on the panel and "Err" on the Main Digits. During the alarm, device outputs will be closed. To eliminate the alarm "Universal Input" should be set to "Not Used".

Configuration Menu Parameters

No.	Name of Parameter	Parameter Definition	Default
P1	Hardware Version	Device hardware version	2.0
P2	Firmware Version	Device firmware version	1.3
P3	Setpoint High Limit	Range: 5°C ... 40°C (Range: 41°F ... 104°F)	30°C (86°F)
P4	Setpoint Low Limit	Range: 5°C ... 40°C (Range: 41°F ... 104°F)	5°C (41°F)
P5	Main Screen	0 = Room temperature 1 = Setpoint temperature 2 = Room Temperature and Setpoint Temperature are displayed in sequence	0
P6	Key Lock	0 = Unlocked 1 = Lock On/Off 2 = Lock Mode 4 = Lock Setpoint 8 = Lock Fan Speed 16 = Lock Time Settings 32 = Lock Time Schedule Settings 63 = Locked All (*) To lock two or more buttons at the same time; sum the numbers of the buttons. To lock setpoint and fan speed, 4 (Setpoint) and 8 (Fan Speed) should be added and written 12.	0
P7	Celsius or Fahrenheit	0 = Celsius 1 = Fahrenheit	0
P8	Time Format	0 = 24 hours clock 1 = 12 hours clock (AM/PM) (*) The system Time Format is 24 hours clock. This parameter adjusts how to clock format on the panel/screen will shows.	1
P9	Time Schedule Enable	0 = Disable 1 = Enable	0
P10	Screen Saver	0 = Screen Saver Disabled 1 = Display On 2 = Display Off 3 = Main Screen Temperature 4 = Main Screen and Clock 5 = Room Temperature and Setpoint are displayed in sequence with the Clock (*) When "2" is selected for the main screen, the room temperature is displayed instead of the main screen in the 3rd and 4th parameters.	4
P11	Screen Saver Mode Delay	Range: 10 ... 150 seconds	60 sec.
P12	LCD Brightness	Range: 1 ... 5 stage	5
P13	Buzzer Stage	Range: 0 ... 5 stage	3
P14	Power Failure	This parameter adjusts the condition that the device will continue after the power failure. 0 = Device starts off 1 = Device starts on 2 = Keep State Before Power Failure	2
P15	Screen Off State Status	0 = Screen off 1 = Room Temperature 2 = Room Temperature and Off 3 = Room Temperature and Clock	1
P16 P27	Reserved	-	-

P28	Cooling Mode Shutdown	0 = Default 1 = Cooling Mode Off	0
P29	Fan Operating Temperature	If P32 = 6, it can take values between 20°C ... 50°C. (If P32 = 6, it can take values in the range of 68°F ... 122°F.)	30
P30	Trench Heater Type	2 = 2 pipe system 4 = 4 pipe system	4
P31	Internal Temperature Sensor Calibration	Range: -10°C ... 10°C and 0.1°C steps (Range: -18°F ... 18°F and 1°F steps)	0°C (0°F)
P32	Universal Input	0 = Not used 1 = External Temperature sensor for room (NTC 10K) 2 = External temperature sensor (NTC 10K) (Monitoring purpose) 3 = Changeover sensor (NTC 10K) 4 = Windows contact/Energy saving-On/Off (NC Contact) 5 = Windows contact/Energy saving-Off/On (NO Contact) 6 = Trench Heater Battery Sensor (NTC 10K)	0
P33	Changeover Temperature for Cooling	Range: 10°C ... 25°C. Only valid when P32 is set to 3 (Range: 50°F ... 77°F. Only valid when P32 is set to 3)	16°C (60°F)
P34	Changeover Temperature for Heating	Range: 26°C ... 45°C. Only valid when P32 is set to 3 (Range: 78°F ... 113°F. Only valid when P32 is set to 3)	28°C (82°F)
P35	Mode Change Delay	Range: 0 ... 255 minutes	3 min.
P36	Universal Input Temperature	If P32 is "1", "2" or "3", this parameter shows the sensor temperature.	0°C (0°F)
P37	Universal Input Temperature Calibration	Range: -10°C ... 10°C and 0.1°C steps (Range: -18°F ... 18°F and 1°F steps)	0°C (0°F)
P38	Auto Mode Enable	0 = Disable 1 = Enable Only valid when P30 is set to 4	1
P39	Dead Zone	Range: 0°C ... 15°C. Only valid when P38 is set to 1 (Range: 0°F ... 27°F. Only valid when P38 is set to 1)	2°C (3°F)
P40	Hysteresis	Range: 0°C ... 15°C (Range: 0°F ... 27°F)	1°C (1°F)
P41	Fan/Valve Control Selection	0 = Valve independent 1 = Valve dependent	1
P42	Fan Stage Selection	1 = 1 Stage 3 = 3 Stage 5 = 5 Stage	5
P43	Fan Minimum Stage Value	Range: 0 ... 100 => 0V ... 10V	0
P44	Fan Maximum Stage Value	Range: 0 ... 100 => 0V ... 10V	100
P45	Proportional Band	Range: 1 ... 100 => 0.1°C ... 10°C	20
P46	Reset Time	Range: 0 ... 100 minutes	30 min.
P47	Fan Start-Up Time	Range: 0 ... 30 seconds	3 sec.
P48	Fan Off Delay	Range: 0 ... 60 seconds	0 sec.
P49	BMS Icon Enable	0 = Disable 1 = Enable	1
P50	Restore Factory Setting	0 = Factory Setting Disable 1 = Factory Setting Started	0
P51	Baudrate	1 = 9600bps 2 = 19200bps 3 = 38400bps 4 = 76800bps	2
P52	Parity	0 = Odd 1 = Even 2 = None	1
P53	Slave Address	Range: 001 ... 247	1

P54	Parameter Menu Password	Range: 001 ... 999 (Read Only)	203
------------	-------------------------	-----------------------------------	-----

Modbus Parameters

Slave Address: 1 ... 247. **Default 1**

Baudrate : 9600, 19200, 38400, 76800. **Default 19200**

Parity : Odd, Even, None. **Default Even**

Note: Slave address, baud rate, and parity changes will be valid after the power reset.

End of Line (EOL) Resistor

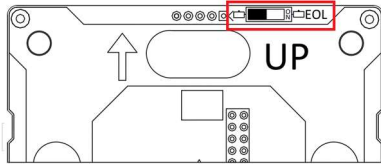

When the thermostat's front plate is flipped, the DIP switch of the EOL resistor is seen on the upper right side of the back plate. When the End of Line (EOL) resistor is needed to be used, the DIP Switch position should be switched to ON.



OFF Position



ON Position

TH300.31 Modbus Registers

Address (Decimal)	Parameter Name	Read (R)/ Write (W)	Default	Min	Max	Description
0	Hardware Version	R	17	0	999	Device hardware version 20 => 2.0
1	Firmware Version	R	13	0	999	Device firmware version 12 => 1.2
2	Start/Stop	R/W	1	0	1	0 = Stop 1 = Start
3	Mode	R/W	3	0	3	0 = Fan Only 2 = Cool 1 = Heat 3 = Auto
4	Fan Speed	R/W	1	1	6	1 = Stage 1 2 = Stage 2 3 = Stage 3 4 = Stage 4 5 = Stage 5 6 = Auto
5	Set Point	R/W	210 (698)	Set Point Low Limit	Set Point High Limit	This parameter is the desired room temperature value. 210 => 21.0°C (698 => 69.8°F)
6	Set Point High Limit	R/W	300 (860)	50 (410)	400 (1040)	This parameter adjusts the high limit for desired room temperature. 50 ... 400 => 5°C ... 40°C (410 ... 1040 => 41°F ... 104°F)
7	Set Point Low Limit	R/W	50 (410)	50 (410)	400 (1040)	This parameter adjusts the low limit for desired room temperature. 50 ... 400 => 5°C ... 40°C (410 ... 1040 => 41°F ... 104°F)
8	Main Screen	R/W	0	0	2	0 = Room temperature 1 = Setpoint temperature 2 = Room Temperature and Setpoint Temperature shown in sequence

9	Key Lock	R/W	0	0	63	<p>0 = Unlocked 1 = Lock On/Off 2 = Lock Mode 4 = Lock Setpoint 8 = Lock Fan Speed 16 = Lock Time Settings 32 = Lock Time Schedule Settings 63 = Locked All (*) To lock two or more buttons at the same time; sum the numbers of the buttons. To lock setpoint and fan speed, 4 (Setpoint) and 8 (Fan Speed) should be added and written 12.</p>
10	Celsius or Fahrenheit	R/W	0	0	1	<p>0 = Celsius 1 = Fahrenheit</p>
11	Time Format	R/W	1	0	1	<p>0 = 24 hours clock 1 = 12 hours clock (AM/PM) (*) The system Time Format is 24 hours clock. This parameter adjusts how the clock format on the panel/screen will appear.</p>
12	Time Schedule Enable	R/W	0	0	1	<p>0 = Disable 1 = Enable</p>
13	Screen Saver	R/W	4	0	5	<p>0 = Screen Saver Disabled 1 = Display On 2 = Display Off 3 = Main Screen Temperature 4 = Main Screen and Clock 5 = Swap Room Temperature and Setpoint with Clock (*) When "2" is selected for the main screen, the room temperature is displayed instead of the main screen in the 3rd and 4th parameters.</p>
14	Screen Saver Mode Delay	R/W	60 sec.	10 sec.	150 sec.	This parameter controls the delay time of the screen saver.
15	LCD Brightness	R/W	5	1	5	This parameter controls the backlight of the panel.
16	Buzzer Stage	R/W	3	0	5	This parameter adjusts the level of the buzzer sound.
17	Power Failure	R/W	2	0	2	<p>This parameter adjusts the condition that the device will continue after the power failure. 0 = Device starts off 1 = Device starts on 2 = Keep State Before Power Failure</p>

18	Screen Off State Status	R/W	1	0	3	0 = Screen off 1 = Room Temperature 2 = Room Temperature and Off 3 = Room Temperature and Clock
19	Time Schedule Local and Remote Selection	R/W	0	0	1	0 = Time Schedule Local 1 = Time Schedule Remote
20 32	Reserved	-	-	-	-	-
33	Trench Heater Type	R/W	4	2	4	2 = 2 Pipe System 4 = 4 Pipe System
34	Room Temperature	R	-	-99 (141)	999 (2118)	This parameter shows the room temperature value. -99 ... 999 => -9.9°C ... 99.9°C (141 ... 2118 => 14.1°F ... 211.8°F)
35	Internal Temperature Sensor Calibration	R/W	0 (0)	-100 (-180)	100 (180)	-100 ... 100 => -10°C ... 10°C (-180 ... 180 => -18°F ... 18°F)
36	Universal Input	R/W	0	0	5	0 = Not used 1 = External Temperature sensor for room (NTC 10K) 2 = External temperature sensor (NTC 10K) (Monitoring purpose) 3 = Changeover sensor (NTC 10K) 4 = Windows contact/Energy saving-On/Off (NC Contact) 5 = Windows contact/Energy saving-Off/On (NO Contact) 6 = Trench Heater Battery Sensor (NTC 10K)
37	Changeover Temperature for Cooling	R/W	160 (608)	100 (500)	250 (770)	If "Universal Input" is set to 3, this parameter adjusts changeover temperature for cooling mode. 100 ... 250 => 10°C ... 25°C (500 ... 770 => 50°F ... 77°F)
38	Changeover Temperature for Heating	R/W	280 (824)	260 (788)	450 (1130)	If "Universal Input" is set to 3, this parameter adjusts changeover temperature for heating mode. 260 ... 450 => 26°C ... 45°C (788 ... 1130 => 78.8°F ... 113°F)
39	Mode Change Delay	R/W	3 min.	0 min.	255 min.	This parameter adjusts delay time between heat and cool modes.
40	Universal Input Temperature	R	-	-99 (141)	999 (2118)	If "Universal Input" is "1", "2" or "3", this parameter shows the sensor temperature. -99 ... 999 => -9.9°C ... 99.9°C (141 ... 2118 => 14.1°F ... 211.8°F)
41	Universal Input Temperature Calibration	R/W	0 (0)	-100 (-180)	100 (180)	-100 ... 100 => -10°C ... 10°C (-180 ... 180 => -18°F ... 18°F)
42	Universal Input Digital Input Value	R	-	0	1	0 = Off 1 = On
43	Auto Mode Enable	R/W	1	0	1	0 = Disable 1 = Enable

						Only valid when "Trench Heater Type" is set to 4
44	Dead Zone	R/W	20 (36)	0 (0)	150 (270)	If "Mode" is set to Auto, this parameter adjusts dead zone. 0 ... 150 => 0°C ... 15°C (0 ... 270 => 0°F ... 27°F)
45	Hysteresis	R/W	10 (18)	0 (0)	150 (270)	This parameter adjusts hysteresis. 0 ... 150 => 0°C ... 15°C (0 ... 270 => 0°F ... 27°F)
46	Fan/Valve Control Selection	R/W	1	0	1	0 = Valve Independent 1 = Valve Dependent
47	Fan Stage Selection	R/W	5	1	5	1 = 1 Stage 3 = 3 Stage 5 = 5 Stage
48	Fan Minimum Stage Value	R/W	0	0	100	Range: 0 ... 100 => 0V ... 10V
49	Fan Maximum Stage Value	R/W	100	0	100	Range: 0 ... 100 => 0V ... 10V
50	Proportional Band	R/W	20	1	100	This parameter determines proportionally the output value of the fan depending on the difference between Room Temperature and Set Point. When the difference between Room Temperature and Set Point equals the value entered in this parameter, the fan output is increased to the maximum fan level value. Range: 1 ... 100 => 0.1°C ... 10°C
51	Reset Time	R/W	30 min.	0 min.	100 min.	When the time specified in this parameter is exceeded, the fan output value equal to the fan output value produced due to the proportional band is produced. (*) If this value is set to "0", the device operates only according to the proportional band value.
52	Fan Start-Up Time	R/W	3 sec.	0 sec.	30 sec.	To guarantee a safe start-up of the fan, this parameter determines, how long the fan will stay at the fan maximum stage value at the start-up time.
53	Fan Off Delay	R/W	0 sec.	0 sec.	60 sec.	This parameter adjusts the closing time delay of the fan.
54	Alarm	R	0	0	3	This parameter indicates the alarm state. 0 = No alarm 1 = Internal Sensor Alarm 2 = External Sensor Alarm 3 = Changeover Sensor Alarm
55	BMS Icon Enable	R/W	1	0	1	0 = Disable 1 = Enable
56	VA1 status	R	-	0	1	0 = Valve Closed 1 = Valve Opened
57	VA2 status	R	-	0	1	0 = Valve Closed 1 = Valve Opened

58	Fan Output Value	R	0	0	100	Range: 0 ... 100 => 0V ... 10V
59	Monday Start Time	R/W	0	0	2359	The hour and minute values written in this parameter are set to turn on the device on Monday.
60	Monday Stop Time	R/W	0	0	2359	The hour and minute values written in this parameter are set to turn off the device on Monday.
61	Tuesday Start Time	R/W	0	0	2359	The hour and minute values written in this parameter are set to turn on the device on Tuesday.
62	Tuesday Stop Time	R/W	0	0	2359	The hour and minute values written in this parameter are set to turn off the device on Tuesday.
63	Wednesday Start Time	R/W	0	0	2359	The hour and minute values written in this parameter are set to turn on the device on Wednesday.
64	Wednesday Stop Time	R/W	0	0	2359	The hour and minute values written in this parameter are set to turn off the device on Wednesday.
65	Thursday Start Time	R/W	0	0	2359	The hour and minute values written in this parameter are set to turn on the device on Thursday.
66	Thursday Stop Time	R/W	0	0	2359	The hour and minute values written in this parameter are set to turn off the device on Thursday.
67	Friday Start Time	R/W	0	0	2359	The hour and minute values written in this parameter are set to turn on the device on Friday.
68	Friday Stop Time	R/W	0	0	2359	The hour and minute values written in this parameter are set to turn off the device on Friday.
69	Saturday Start Time	R/W	0	0	2359	The hour and minute values written in this parameter are set to turn on the device on Saturday.
70	Saturday Stop Time	R/W	0	0	2359	The hour and minute values written in this parameter are set to turn off the device on Saturday.
71	Sunday Start Time	R/W	0	0	2359	The hour and minute values written in this parameter are set to turn on the device on Sunday.
72	Sunday Stop Time	R/W	0	0	2359	The hour and minute values written in this parameter are set to turn off the device on Sunday.
73	Current Year	R/W	2019	2017	2099	This parameter adjusts the current year.
74	Current Month	R/W	-	1	12	This parameter adjusts the current month.
75	Current Day	R/W	-	1	31	This parameter adjusts the current day.
76	Current Hour	R/W	-	00	23	This parameter adjusts the current hour.
77	Current Minute	R/W	-	00	59	This parameter adjusts the current minute.
78	Restore Factory Setting	R/W	0	0	1	0 = Factory Setting Disable 1 = Factory Setting Started

79	Baudrate	R/W	2	1	4	1 = 9600bps 2 = 19200bps	3 = 38400bps 4 = 76800bps
80	Parity	R/W	1	0	2	0 = Odd 1 = Even 2 = None	
81	Slave Address	R/W	1	1	247	This parameter is used to adjust the address of the device.	
82	Parameter Menu Password	R/W	203	1	999	This parameter sets the parameter menu password.	

Dimension (mm)

