

**T3065.31**

**Touch Button EC Proportional Fan Coil Thermostat**



For 2-pipe and 4-pipe Fan Coil Units

**Features**

- Manual or automatic fan control with selectable stages
- Proportional control heating/cooling valves
- 6-Ways Valve Control
- Auto, Heat, Cool and Ventilation modes
- Economy Mode
- Manual or automatic heating/cooling changeover
- Fan Only, Heating and Fan, Cooling and Fan options
- On/off electric heater control
- Universal input for external sensor or windows/energy saving contact etc.
- Automatic heating/cooling changeover via changeover sensor
- Automatic heating/cooling changeover via changeover contact
- Remote On/Off via contact
- User setpoint limitation
- Clock and time schedule functions
- Key lock
- Configurable user parameters
- Modbus RTU communication
- Modern styling and capacitive touch buttons
- White backlight LCD
- Different colour options; black and white
- EU box flush-mount



**Applications**

T30x5 Series Fan Coil Thermostats is used in individual rooms or zones in buildings. It is designed for two and four pipe fan coil units. T3065 has one universal input that can be used as an external sensor or open/close contact input, three analog outputs, one relay output and one RS-485 port. It controls the fan coil unit depending on the internal room sensor or external return sensor temperature.

**Notes on Usage**

Please, read this datasheet carefully. T3065 thermostat is designed and manufactured in accordance with latest technological developments and safety. To avoid injury and property damage, safety warnings must be observed.

**Security Advice-Caution**

Assembly, maintenance, and repair must be done by authorized service. The power supply of the device is 24 V AC/DC and it has no internal fuse. External protection with max C 5 A circuit breaker required in all cases. Disconnect from power supply before separating front plate.



**Ordering Information**

Product Code	Description	Power	Communication
T3065.31	1 Analog Output (0-10 V) Fan Control 2 Analog Outputs (0-10 V) Valve Control 1 Digital Output (Relay) Electrical Heater Control 1 Universal Input 1 RS-485 Port	24 V AC/DC	Modbus RTU

**Technical Specification**

Power Supply	24 V AC/DC
Power Consumption	Max ~3.0 VA
Electrical Connection	Terminal Connectors
Battery for Real Time Clock (RTC)	Lithium CR1220 3.3V
Measuring Range	-10°C ... +100°C (+14°F ... +212°F)
Resolution	0.1°C (1°F)
Inputs	1 Universal Input (NTC 10K or Dry Contact)
Outputs	3 Analog Outputs (0-10 V), 1 Digital Output (5 (2) A Relay)
Communication	1 x RS-485 Port
Temperature Setting	5°C ... 40°C (Adjustable) (41°F ... 104°F (Adjustable))
Dimensions	86 x 86 x 52 mm
Mounting	Flush Mounted (Standard EU box)

**Mounting Location**

Thermostat is suggested to be installed indoor, a place with around 1.5m height above the floor where represents the average room temperature. It should be away from direct sunlight, any cover or any heat source, to avoid false signal for temperature control.



**CAUTION: Power off supply at circuit breaker or fuse before installation to avoid fire, shock or death!**

## Mounting Instructions

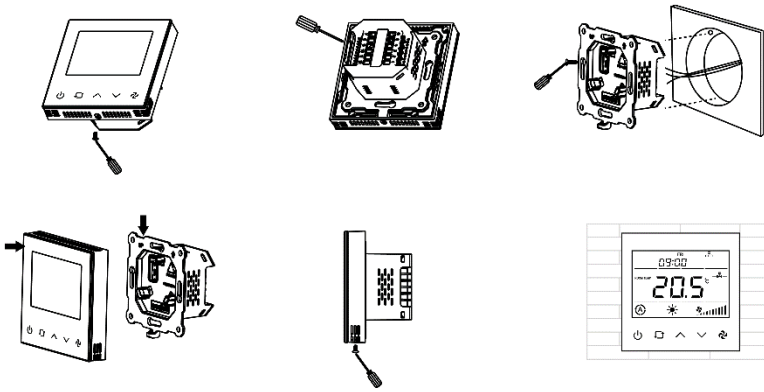

Please follow below instructions during mounting.

**Step 1:** Take the thermostat out from the package. Get the datasheet inside the package.

**Step 2:** Connect the wires properly according to the wiring diagram below.

**Step 3:** Separate the front plate and the back plate, and then use screwdriver to fix the back plate into the electric box with 4 screws.

**Step 4:** Attach the front plate to the back plate, making sure the pin plates on each side are well matched.

**Step 5:** Compare it with the pictures after installation.

**Step 6:** Power on the thermostat to work.

**Important Note 1:** It is recommended to use the following flush mount boxes for better mounting:

Alternative 1: Manufacturer: Viko by Panasonic, Part Number: 90926006 (Depth must be minimum 50 mm!)

Alternative 2: Manufacturer: Legrand, Part Number: 0 801 21 (Depth must be minimum 50 mm!)

**Important Note 2:** It is recommended to use the screws included in the product box. Otherwise, there could be fitting problems during the mounting.

Connection Diagrams

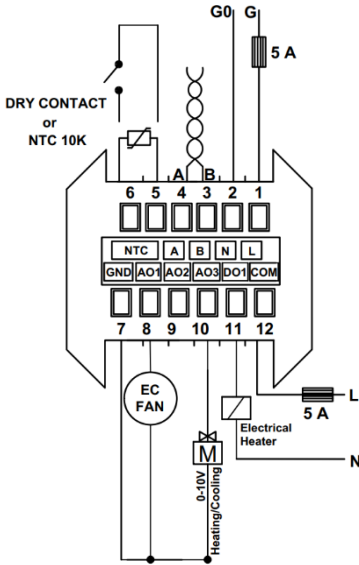

Connection Diagram for 2-Pipe Fan Coil and 6-Way Valve

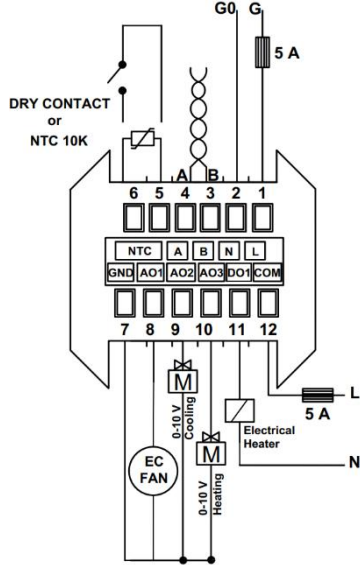

Connection Diagram for 4-Pipe Fan Coil

**Note:** Thermostat has no internal fuse. External protection with max C 5 A circuit breaker required in all cases. Isolate the cables of NTC – dry contact from 24 V power supply.

**Display and Operations**

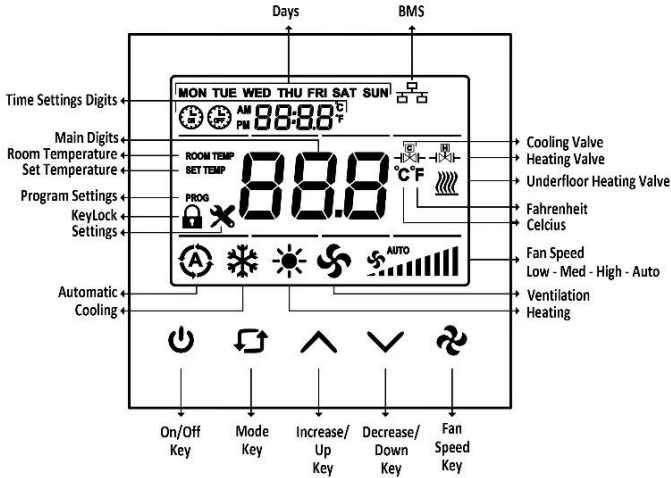

- **Mode Selection:** Press the **MODE** key to change the mode of the device. Active mode options are as follows.

	AUTOMATIC	COOL	HEAT	FAN
FAN ONLY	-	-	-	√
COOLING + FAN	-	√	-	√
2 PIPE SYSTEM	-	√	√	√
HEATING + FAN	-	-	√	√
4 PIPE SYSTEM	√	√	√	√
6 WAY VALVE SYSTEM	√	√	√	√

- **Fan Selection:** When the **FAN SPEED** key is pressed, fan speed can be changed as Stage 1, Stage 2, Stage 3, Stage 4, Stage 5, Auto. The fan can be selected as 1 stage, 3 stage or 5 stage via parameter P44.

- **Time Settings:** After pressing the **MODE** key for 3 seconds, year digits flashes on the panel. **MODE** key is pressing once again, month digit flashes on the panel. **MODE** key is pressed once again, day digit flashes on the panel. **MODE** key is pressed once again, hour digit flashes on the panel. **MODE** key is pressed once again, minute digit flashes on the panel. **MODE** key is pressed once again, day of week digit flashes on the panel. Year, month, day, hour, minute, day of week information are be changed by **INCREASE** and **DECREASE** keys.

**Order:** Year -> Month -> Day -> Hour -> Minute -> Day Of Week

- **Schedule Operations:** Be sure to set the time settings, before making schedule operations. After setting the day, to enter the Schedule menu, press the **MODE** key one time. While in the Schedule menu, "**Monday opening time hour digit**" flashes on the panel. When the **MODE** key is pressed once again, "**Monday opening time minute digit**" flashes on the panel. Then, when the **MODE** key is pressed one more time, "**Monday closing time hour digit**" flashes on the panel. After that when the **MODE** key is pressed once again, "**Monday closing time minute digit**" flashes on the panel. While the digits flashing, hour and minute can be changed by **INCREASE** and **DECREASE** keys. Use the **MODE** key to set the other days' schedule.

**Note:** When the time schedule is set, the on/off lock will be activated.

- Key Lock Operations:** Pressing both **MODE** and **INCREASE** keys, key lock digit displays on the panel. The panel is locked. When the panel is locked, press the **MODE** and **INCREASE** keys to unlock panel. "Key Lock" options can be changed via parameter P6. To lock two or more keys at the same time; sum the numbers of the keys. To lock mode key and on/off key, 1 (on/off) and 2 (mode) should be added and written 3 to parameter P6. To lock setpoint and fan speed, 4 (setpoint) and 8 (fan speed) should be added and written 12 to parameter P6.

## Configuration

### Configuration Menu Description

When the device is on or off position, press together **Main Parameter Increase Key** and **Value Decrease Key** for 3 seconds, to enter the Configuration Menu. In the password screen, Password digits can be changed by **Main Parameter Increase Key**, Password value can be changed by **Value Increase Key** and **Value Decrease Key**. Password must be entered as "203" and **Main Parameter Decrease Key** must be pressed to confirm. When the correct password is written, the configuration menu will be entered. If the wrong password is entered, it will fail, and the password will reset. Password screen will return to main screen without an action 10 seconds. Parameter setting screen will return to main screen without any action in 30 seconds. All parameters are stored within device memory ensuring no data loss if the Thermostat is powered off.

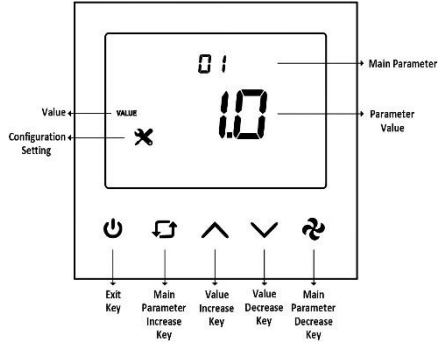

### Energy Saving Mode (ECO Mode) (Parameter P19 or via Modbus)

Economy mode is activated from the authorization point (P19). When economy mode authorization is activated, the device will operate in economy mode instead of OFF state. In ECO mode, the system will operate according to the set point value for heating and cooling.

The situations that will be affected by the economy mode are as follows;

- Auto mode authorization will be turned off.
- Fan/Valve control will operate as Valve Dependent.

**Note:** Economy mode will not be activated when Universal Input is selected Changeover.

### Temperature Input Selection Parameter (Parameter P26 or via Modbus)

- Internal Room Temperature Sensor (parameter P26 = 0)

The system takes the Internal Temperature Sensor as reference. If Universal Input is selected as "1", the system takes the Universal input as reference.

-BMS Room Temperature and Internal Room Temperature Sensor (parameter P26 = 1)

The system takes the value entered from the BMS as reference. If the BMS communication is lost and does not return within five minutes, the system gives an alarm but continues to operate according to the Internal Temperature sensor. If the BMS communication returns, system takes the BMS value as a reference and continues to work.

-BMS Room Temperature (parameter P26 = 2)

The system takes the value entered from the BMS as reference. If the BMS communication is lost, the system gives an alarm and turns off all outputs. It continues to work in the case of communication.

**6-Way Valve (Parameter P32 or via Modbus)**

6-way valve operation diagram is as follows;

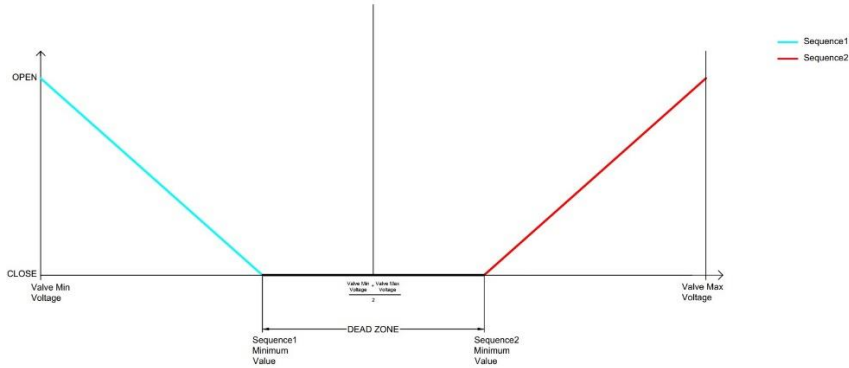

Sequence 1 is set as the default cooling valve. For Sequence 1 to operate in heating mode, it can be done by changing the Valve1 direction parameter.

The dead band mentioned in the graph is the 6-way valve dead zone parameter. (P 25)

\*Dead band is divided equally in Sequence 1 and Sequence 2 plots.

e.g. The midpoint on a 0-10 valve is 5 volts. If the 6-way valve dead band parameter is 2, the minimum value of sequence 1 is  $5 - (2/2) = 4$ . Sequence 2 minimum value is also  $5 + (2/2) = 6$ .

**Universal Input Parameter (Parameter P34 or via Modbus)**

- External Sensor for room (parameter P34 = 1)

The device operates according to external temperature sensor value read from universal input.

- External Sensor (parameter P34 = 2)

The device operates according to internal temperature sensor value. The temperature read from the universal input can be monitored from **P38** and related BMS point.

- Changeover Sensor (parameter P34 = 3)

If "Universal Input" value is selected as changeover, "dead zone" cannot be used.

Changeover sensor only valid when "Fan Coil Type" is set to 2.

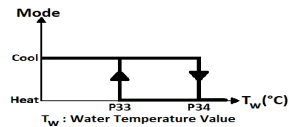

When the water temperature is above **P35** the thermostat changes over to heating mode. It stays in heating mode until the temperature falls below **P36**. When the water temperature is below **P35**, the thermostat changes over to cooling mode. It stays in cooling mode until the temperature rises above **P36**.

- Changeover contact-On/Off (NC Contact) (parameter P34 = 4)

Changeover sensor only valid when "Fan Coil Type" is set to 2.

When this contact is closed, the device will operate according to the cooling mode. When the contact is opened, it will operate according to the heating mode.

- Changeover contact-Off/On (NO Contact) (parameter P34 = 5)

Changeover sensor only valid when "Fan Coil Type" is set to 2.

When this contact is opened, the device will operate according to the cooling mode. When the contact is closed, it will operate according to the heating mode.

- Windows contact/Energy saving-On/Off (NC Contact) (parameter P34 = 6)

When this contact is closed, the device is in the "ON" position. When this condition is not met, the device shows "OPEN" on the panel and the outputs of the device are passive.

- Windows contact/Energy saving-Off/On (NO Contact) (parameter P34 = 7)

When this contact is opened, the device is in the "ON" position. When this condition is not met, the device shows "OPEN" on the panel and the outputs of the device are passive.

- Remote Control (NC Contact) (parameter P34=8)

When this contact is open, the device is in the "Off-ECO" position. When the contact is turned off, the device will switch to the "On" position. In this case, On/Off key will be locked, it will not be able to be written via Modbus and the Time Schedule will be disabled.

- Remote Control (NO Contact) (parameter P34=9)

When this contact is closed, the device is in the "Off-ECO" position. When the contact is turned on, the device will switch to the "On" position. In this case, On/Off key will be locked, it will not be able to be written via Modbus and the Time Schedule will be disabled.

- Remote Off-ECO (NC Contact) (parameter P34=10)

When this contact is open, the device is in the "Off-ECO" position. If the contact is closed, the device will continue to operate in its previous position. When the device is in the "Off" position, On/Off key will be locked, it will not be able to be written via Modbus and the Time Schedule will be disabled.

- Remote Off-ECO (NO Contact) (parameter P34=11)

When this contact is closed, the device is in the "Off-ECO" position. If the contact is open, the device will continue to operate in its previous position. When the device is in the "Off" position, On/Off key will be locked, it will not be able to be written via Modbus and the Time Schedule will be disabled.

- Heater Contact (NC Contact) (parameter P34 = 12)

When this contact is opened, the electrical heater output is closed. The device shows "AL 04" on the panel.

- Heater Contact (NO Contact) (parameter P34 = 13)

When this contact is closed, the electrical heater output is closed. The device shows "AL 04" on the panel.

### Hysteresis (Parameter P42 or via Modbus)

The output diagram of the valve according to the relation between  $T_S$  and  $T_R$  is given below.

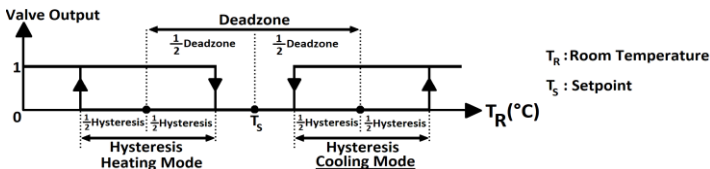

### Fan/Valve Control Selection (Parameter P43 or via Modbus)

In valve independent mode, the fan operates according to manual fan selection or automatic fan control. When valve is closed, the fan will continue to operate.

In valve dependent mode, the fan will be closed when the valve is closed. If the valve is open, the fan will operate according to manual fan selection or automatic fan control.



### Fan Stage Selection (Parameter P44 or via Modbus)

The thermostat fan speed can be adjusted as 1, 3 or 5 stage via P44 or via Modbus. The minimum and maximum fan speed output values can be adjusted via P45 and P46, respectively.

### Fan Output Value Calculation (via Modbus)

Fan output value is calculated as below;

Fan Output Value in Fan Stage X = Fan Minimum Stage Value + Value \* Fan Stage X

Value is calculated below;

Value = (Fan Maximum Stage Value – Fan Minimum Stage Value) / Fan Stage Selection

For Example;

Fan Minimum Stage Value (Parameter P45 or via Modbus) = 20

Fan Maximum Stage Value (Parameter P46 or via Modbus) = 80

Fan Stage Selection (Parameter P42 or via Modbus) = 3

Value = (80 - 20) / 3 = 20

Fan Output Value in Fan Stage 1 = 20 + 20 \* 1 = 40

Fan Output Value in Fan Stage 2 = 20 + 20 \* 2 = 60

Fan Output Value in Fan Stage 3 = 20 + 20 \* 3 = 80

### Restore Factory Setting (Parameter P52 or via Modbus)

The device can load the factory setting parameters via parameter P52, by changing the value to “1”, and pressing button **Exit** Key. While in the factory reset process, lines on the top and the bottom will be running from left to right for 3 seconds. The display shows top and bottom lines loaded step by step during reload process approximately 3 seconds.

### Alarms

Alarm Code will appear on the screen, during alarm. If one of the alarm conditions is met. Alarm Codes will appear on the screen alternately. If more than one alarm condition is met.

- Onboard Sensor Alarm:

If the internal temperature sensor fails, “**AL 01**” will appear on the screen and “Err” will be shown on the main digits. During the alarm, device outputs will be closed. If the “Universal Input” is selected to “External Sensor”, the device continues normal operation.

- External Sensor Alarm:

If the “Universal Input” parameter is set to “External Temperature Sensor” and sensor is not connected or connection breaks down, “**AL 02**” will appear on the screen and “Err” will be shown on the main digits. During the alarm, device outputs will be closed. “Universal Input” is set to “Not Used” to eliminate the alarm.

- Changeover Sensor Alarm:

If the “Universal Input” is selected to “Changeover Sensor” also the sensor is broken down, displayed “**AL 03**” on the panel and “Err” on the Main Digits. During the alarm, device outputs will be closed. “Universal Input” is set to “Not Used” to eliminate the alarm.

- Heater Contact Alarm

If the “Universal Input” is selected to “Heater Contact (NO-NC)” also the contact is broken down, displayed (if NO is selected the connection is short circuit) “**AL 04**” on the panel. During the alarm, device heater output will be closed.

-BMS Temperature Input Alarm:

If the “Temperature Input Selection” parameter is selected as “1”, BMS communication gets lost and if it does not return within 5 minutes, “**AL 05**” alarm will be displayed on the screen. The system will take the Internal Temperature Sensor value as the reference temperature. When the BMS communication is returned, the BMS temperature value will be referenced again, and the alarm will disappear.

If BMS communication is lost when "Temperature Input Selection" parameter is "2", "AL 05" alarm and "Err" in Main Digits will be displayed on the screen. The device turns off its outputs in case of alarm. To eliminate the alarm, BMS communication must be made, or "Temperature Input Selection" parameter must be selected as "0".

### Configuration Menu Parameters

No.	Name of Parameter	Parameter Definition	Default
P1	Hardware Version	Device hardware version	2.1
P2	Firmware Version	Device firmware version	1.6
P3	Setpoint High Limit	Range: 5°C ... 99.9°C (Range: 41°F ... 212°F)	30°C (86°F)
P4	Setpoint Low Limit	Range: 5°C ... 99.9°C (Range: 41°F ... 212°F)	5°C (41°F)
P5	Main Screen	0 = Room temperature 1 = Setpoint temperature 2 = Swap Room Temperature and Setpoint Temperature	0
P6	Key Lock	0 = Unlocked 1 = Lock On/Off 2 = Lock Mode 4 = Lock Setpoint 8 = Lock Fan Speed 16 = Lock Time Settings 32 = Lock Time Schedule Settings 63 = Locked All  (* ) To lock two or more keys at the same time; sum the numbers of the keys. To lock setpoint and fan speed, 4 (Setpoint) and 8 (Fan Speed) should be added and written 12.	0
P7	Celsius or Fahrenheit	0 = Celsius 1 = Fahrenheit	0
P8	Time Format	0 = 24 hours clock 1 = 12 hours clock (AM/PM)  (* ) The system Time Format is 24 hours clock. This parameter adjusts how to clock format on the panel/screen will shown.	1
P9	Time Schedule Enable	0 = Disable 1 = Enable	0
P10	Screen Saver	0 = Screen Saver Disabled 1 = Display On 2 = Display Off 3 = Main Screen Temperature 4 = Main Screen and Clock 5 = Room Temperature and Setpoint alternately, and Clock  (* )When the Main Screen parameter is set to "2", Room Temperature appears instead of Main Screen at the 3. and 4. parameters	4
P11	Screen Saver Mode Delay	Range: 10 ... 150 seconds	60 sec.
P12	LCD Brightness	Range: 1 ... 5 stages	5
P13	Buzzer Stage	Range: 0 ... 5 stages	3
P14	Power Failure	This parameter adjusts the condition that the device will continue when the power failure. 0 = Device starts off 1 = Device starts on 2 = Keep State Before Power Failure	2
P15	Screen Off State Status	0: Screen off 1: Room Temperature 2: Room Temperature and Off 3: Room Temperature and Clock	1
P16	Valve Proportional Band	Range: 1 ... 100 => 0.1°C ... 10°C	20

P17	Electrical Heater Enable	0 = Disable 1 = Enable	0
P18	Electrical Heater Setpoint Differential	Range: 0 ... 150 => 0°C ... 15°C	50
P19	ECO Mode Activation	0 = Eco Mode authorization turned off 1 = Eco Mode authorization turned on	0
P20	ECO Mode Cooling Mode Set Point	Set Point Low Limit ... Set Point High Limit	21°C (69,8°F)
P21	ECO Mode Heating Mode Set Point	Set Point Low Limit ... Set Point High Limit	21°C (69,8°F)
P22 : P24	Reserved	-	-
P25	6 Way Valve Deadband	This parameter determines the deadband value for the 6-way valve.	2
P26	Temperature Input Selection	This parameter determines which input the room temperature will operate according to. 0 = Internal Temperature Sensor/Universal Input 1 = BMS/Internal Temperature Sensor 2 = BMS	0
P27	Valve Minimum Value	It determines the minimum value of the valve outputs. 0 ... 100 => 0V ... 10V	0
P28	Valve Maximum Value	It determines the maximum value of the valve outputs. 0 ... 100 => 0V ... 10V	100
P29	Underfloor Heating Activation	0 = Underfloor heating disable 1 = Underfloor heating enable	0
P30	VA1 Direction	0 = Normal Direct 1 = Reverse Direct	0
P31	VA2 Direction	0 = Normal Direct 1 = Reverse Direct	0
P32	Fan Coil Type	0 = Fan Only 1 = 2 pipe system Cooling + Fan 2 = 2 pipe system 3 = 2 pipe system Heating + Fan 4 = 4 pipe system 6 = 6-Ways valve system	4
P33	Internal Temperature Sensor Calibration	Range: -10°C ... 10°C and 0.1°C steps (Range: -18°F ... 18°F and 1°F steps)	0°C (0°F)
P34	Universal Input	0 = Not used 1 = External Temperature sensor for room (NTC 10K) 2 = External temperature sensor (NTC 10K) (Monitoring purpose) 3 = Changeover sensor (NTC 10K) 4 = Changeover contact-On/Off (NC Contact) 5 = Changeover contact-Off/On (NO Contact) 6 = Windows contact/Energy saving-On/Off (NC Contact) 7 = Windows contact/Energy saving-Off/On (NO Contact) 8 = Remote Control (NC Contact) 9 = Remote Control (NO Contact) 10 = Remote Off (NC Contact) 11 = Remote Off (NO Contact) 12 = Heater Contact (NC Contact) 13 = Heater Contact (NO Contact)	0
P35	Changeover Temperature For Cooling	Range: 10°C ... 25°C. Only valid when P32 is set to 3 (Range: 50°F ... 77°F. Only valid when P32 is set to 3)	16°C (60°F)

<b>P36</b>	Changeover Temperature For Heating	Range: 26°C ... 45°C. Only valid when P32 is set to 3 (Range: 78°F ... 113°F. Only valid when P32 is set to 3)	28°C (82°F)
<b>P37</b>	Mode Change Delay	Range: 0 ... 255 minutes	3 min.
<b>P38</b>	Universal Input Temperature	If P32 is "1", "2" or "3", this parameter shows the sensor temperature.	0°C (0°F)
<b>P39</b>	Universal Input Temperature Calibration	Range: -10°C ... 10°C and 0.1°C steps (Range: -18°F ... 18°F and 1°F steps)	0°C (0°F)
<b>P40</b>	Auto Mode Enable	0 = Disable 1 = Enable Only valid when P32 is set to 4	1
<b>P41</b>	Dead Zone	Range: 0°C ... 15°C. Only valid when P38 is set to 1 (Range: 0°F ... 27°F. Only valid when P38 is set to 1)	2°C (3°F)
<b>P42</b>	Hysteresis	Range: 0°C ... 15°C (Range: 0°F ... 27°F)	1°C (1°F)
<b>P43</b>	Fan/Valve Control Selection	0 = Valve independent 1 = Valve dependent	1
<b>P44</b>	Fan Stage Selection	1 = 1 Stage 3 = 3 Stage 5 = 5 Stage	5
<b>P45</b>	Fan Minimum Stage Value	Range: 0 ... 100 => 0V ... 10V	0
<b>P46</b>	Fan Maximum Stage Value	Range: 0 ... 100 => 0V ... 10V	100
<b>P47</b>	Proportional Band	Range: 1 ... 100 => 0.1°C ... 10°C	20
<b>P48</b>	Reset Time	Range: 0 ... 100 minutes	30 min.
<b>P49</b>	Fan Start-Up Time	Range: 0 ... 30 seconds	3 sec.
<b>P50</b>	Fan Off Delay	Range: 0 ... 60 seconds	0 sec.
<b>P51</b>	BMS Icon Enable	0 = Disable 1 = Enable	1
<b>P52</b>	Restore Factory Setting	0 = Factory Setting Disable 1 = Factory Setting Started	0
<b>P53</b>	Baudrate	1 = 9600bps 2 = 19200bps 3 = 38400bps 4 = 76800bps	2
<b>P54</b>	Parity	0 = Odd 1 = Even 2 = None	1
<b>P55</b>	Slave Address	Range: 001 ... 247	1
<b>P56</b>	Parameter Menu Password	Range: 001 ... 999 (Read Only)	203

### Modbus Parameters

**Slave Address** : 1 ... 247. **Default 1**

**Baudrate** : 9600, 19200, 38400, 76800. **Default 19200**

**Parity** : Odd, Even, None. **Default Even**

**End of Line (EOL) Resistor**

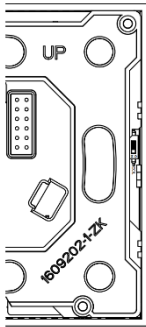

When the thermostat front plate is flipped, the EOL resistor DIP switch is seen on the upper right side of the back plate. This resistor's default position is OFF. When the End of Line (EOL) resistor is needed to be used, DIP Switch position should be switched to ON.

**OFF Position**



**ON Position**



**T3065.31 Modbus Registers**

Address (Decimal)	Parameter Name	Read (R)/ Write (W)	Default	Min	Max	Description
0	Hardware Version	R	21	0	999	Device hardware version 21 => 2.1
1	Firmware Version	R	16	0	999	Device firmware version 16 => 1.6
2	Start/Stop	R/W	1	0	1	0 = Stop 1 = Start
3	Mode	R/W	3	0	3	0 = Fan Only 2 = Cool 1 = Heat 3 = Auto
4	Fan Speed	R/W	1	1	6	1 = Stage 1 2 = Stage 2 3 = Stage 3 4 = Stage 4 5 = Stage 5 6 = Auto
5	Set Point	R/W	210 (698)	Set Point Low Limit	Set Point High Limit	This parameter is the desired room temperature value. 210 => 21.0°C (698 => 69.8°F)
6	Set Point High Limit	R/W	300 (860)	Set Point Low Limit	999 (2120)	This parameter adjusts the high limit for desired room temperature. 50 ... 999 => 5°C ... 99.9°C (410 ... 2120 => 41°F ... 212°F)
7	Set Point Low Limit	R/W	50 (410)	50 (410)	Set Point High Limit	This parameter adjusts the low limit for desired room temperature. 50 ... 999 => 5°C ... 99.9°C (410 ... 2120 => 41°F ... 212°F)
8	Main Screen	R/W	0	0	2	0 = Room temperature 1 = Setpoint temperature 2 = Swap Room Temperature and Setpoint Temperature

9	Key Lock	R/W	0	0	63	<p>0 = Unlocked            1 = Lock On/Off            2 = Lock Mode            4 = Lock Setpoint            8 = Lock Fan Speed            16 = Lock Time Settings            32 = Lock Time Schedule Settings            63 = Locked All</p> <p>(* ) To lock two or more buttons at the same time; sum the numbers of the buttons. To lock setpoint and fan speed, 4 (Setpoint) and 8 (Fan Speed) should be added and written 12.</p>
10	Celsius or Fahrenheit	R/W	0	0	1	<p>0 = Celsius    1 = Fahrenheit</p>
11	Time Format	R/W	1	0	1	<p>0 = 24 hours clock            1 = 12 hours clock (AM/PM)</p> <p>(* ) The system Time Format is 24 hours clock. This parameter adjusts how to clock format on the panel/screen will shows.</p>
12	Time Schedule Enable	R/W	0	0	1	<p>0 = Disable            1 = Enable</p>
13	Screen Saver	R/W	4	0	5	<p>0 = Screen Saver Disabled            1 = Display On            2 = Display Off            3 = Main Screen Temperature            4 = Main Screen and Clock            5 = Room Temperature and Setpoint alternately, and Clock</p> <p>(* )When the Main Screen parameter is set to "2", Room Temperature appears instead of Main Screen at the 3. and 4. parameters</p>
14	Screen Saver Mode Delay	R/W	60 sec.	10 sec.	150 sec.	This parameter controls the screen saver mode delay of the panel.
15	LCD Brightness	R/W	5	1	5	This parameter controls the backlight of the panel.
16	Buzzer Stage	R/W	3	0	5	This parameter adjusts the level of the buzzer sound.
17	Power Failure	R/W	2	0	2	<p>This parameter adjusts the condition that the device will continue when the power failure happens.</p> <p>0 = Device starts off            1 = Device starts on            2 = Keep State Before Power Failure</p>
18	Screen Off State Status	R/W	1	0	3	<p>0: Screen off            1: Room Temperature            2: Room Temperature and Off            3: Room Temperature and Clock</p>
19	Proportional Band for Valve	R/W	20	1	100	<p>This parameter determines proportionally the output value of the fan depending on the difference between Room Temperature and Set Point.</p> <p>Range: 1 ... 100 =&gt; 0.1°C ... 10°C</p>

20	Electrical Heater Enable	R/W	0	0	1	This parameter allows active or passive selection of electrical heater 0 = Electrical Heater Disable 1 = Electrical Heater Enable
21	Electrical Heater Setpoint Differential	R/W	50	0	150	This parameter determines the difference between the desired temperature and the room temperature for switching on the electrical heater. Range: 0 ... 150 => 0°C ... 15°C
22	Electrical Heater Status	R	-	0	1	0 = Electrical Heater Closed 1 = Electrical Heater Opened
23	Time Schedule Local and Remote Selection	R/W	0	0	1	0 = Time Schedule Local 1 = Time Schedule Remote
24	Eco Mode Enable	R/W	0	0	1	0 = Economy Mode authorization turned off 1 = Economy Mode authorization turned off
25	Eco Mode Cooling Set Point	R/W	210 (698)	Set Point Low Limit	Set Point High Limit	This parameter is the Set Point value for ECO MODE Cooling Mode. 210 => 21.0°C (698 => 69.8°F)
26	Eco Mode Heating Set Point	R/W	210 (698)	Set Point Low Limit	Set Point High Limit	This parameter is the Set Point value for ECO MODE Heating Mode. 210 => 21.0°C (698 => 69.8°F)
27	BMS Room Temperature	R/W	225 (725)	50 (410)	999 (2120)	It is the Room Temperature value entered via BMS. 50 ... 999 => 5°C ... 99.9°C (410... 2120 => -41°F ... 212°F)
28	Internal Sensor Temperture	R	-	-99 (141)	999 (2118)	This parameter shows the room temperature value. -99 ... 999 => -9.9°C ... 99.9°C (141 ... 2118 => 14.1°F ... 211.8°F)
29	Internal Temperature Sensor Calibration	R/W	0 (0)	-100 (-180)	100 (180)	-100 ... 100 => -10°C ... 10°C (-180 ... 180 => -18°F ... 18°F)
30	Valve Minimum Value	R/W	0	0	100	It determines the minimum value of the valve outputs. 0 ... 100 => 0V ... 10V
31	Valve Maximum Value	R/W	100	0	100	It determines the maximum value of the valve outputs. 0 ... 100 => 0V ... 10V
32	VA1 Direction	R/W	0	0	1	0 = Normal Direct 1 = Reverse Direct
33	VA2 Direction	R/W	0	0	1	0 = Normal Direct 1 = Reverse Direct
34	Underfloor Heating Activation	R/W	0	0	1	0 = Underfloor heating disable 1 = Underfloor heating enable

35	Fan Coil Type	R/W	4	0	6	0 = Fan Only 1 = 2 pipe system Cooling + Fan 2 = 2 pipe system 3 = 2 pipe system Heating + Fan 4 = 4 pipe system 6 = 6-Ways valve system
36	Room Temperature	R	-	-99 (141)	999 (2118)	This parameter shows the room temperature value. -99 ... 999 => -9.9°C ... 99.9°C (141 ... 2118 => 14.1°F ... 211.8°F)
37	Internal Temperature Sensor Calibration	R/W	0 (0)	-100 (-180)	100 (180)	-100 ... 100 => -10°C ... 10°C (-180 ... 180 => -18°F ... 18°F)
38	Universal Input	R/W	0	0	13	0 = Not used 1 = External Temperature sensor for room (NTC 10K) 2 = External temperature sensor (NTC 10K) (Monitoring purpose) 3 = Changeover sensor (NTC 10K) 4 = Changeover contact-On/Off (NC Contact) 5 = Changeover contact-Off/On (NO Contact) 6 = Windows contact/Energy saving-On/Off (NC Contact) 7 = Windows contact/Energy saving-Off/On (NO Contact) 8 = Remote Control (NC Contact) 9 = Remote Control (NO Contact) 10 = Remote Off (NC Contact) 11 = Remote Off (NO Contact) 12 = Heater over temperature contact (NC Contact) 13 = Heater over temperature contact (NO Contact)
39	Changeover Temperature for Cooling	R/W	160 (608)	100 (500)	250 (770)	If "Universal Input" is set to 3, this parameter adjusts changeover temperature for cooling mode. 100 ... 250 => 10°C ... 25°C (500 ... 770 => 50°F ... 77°F)
40	Changeover Temperature for Heating	R/W	280 (824)	260 (788)	450 (1130)	If "Universal Input" is set to 3, this parameter adjusts changeover temperature for heating mode. 260 ... 450 => 26°C ... 45°C (788 ... 1130 => 78.8°F ... 113°F)
41	Mode Change Delay	R/W	3 min.	0 min.	255 min.	This parameter adjusts delay time between heat and cool modes.
42	Universal Input Temperature	R	-	-99 (141)	999 (2118)	If "Universal Input" is "1", "2" or "3", this parameter shows the sensor temperature. -99 ... 999 => -9.9°C ... 99.9°C (141 ... 2118 => 14.1°F ... 211.8°F)



43	Universal Input Temperature Calibration	R/W	0 (0)	-100 (-180)	100 (180)	-100 ... 100 => -10°C ... 10°C (-180 ... 180 => -18°F ... 18°F)
44	Universal Input Digital Input Value	R	-	0	1	0 = Off 1 = On
45	Auto Mode Enable	R/W	1	0	1	0 = Disable 1 = Enable Only valid when "Fan Coil Type" is set to 4
46	Dead Zone	R/W	20 (36)	0 (0)	150 (270)	If "Mode" is set to Auto, this parameter adjusts dead zone. 0 ... 150 => 0°C ... 15°C (0 ... 270 => 0°F ... 27°F)
47	Hysteresis	R/W	10 (18)	0 (0)	150 (270)	This parameter adjusts hysteresis. 0 ... 150 => 0°C ... 15°C (0 ... 270 => 0°F ... 27°F)
48	Fan/Valve Control Selection	R/W	1	0	1	0 = Valve Independent 1 = Valve Dependent
49	Fan Stage Selection	R/W	5	1	5	1 = 1 Stage 3 = 3 Stage 5 = 5 Stage
50	Fan Minimum Stage Value	R/W	0	0	100	Range: 0 ... 100 => 0V ... 10V
51	Fan Maximum Stage Value	R/W	100	0	100	Range: 0 ... 100 => 0V ... 10V
52	Proportional Band	R/W	20	1	100	This parameter determines proportionally the output value of the fan depending on the difference between Room Temperature and Set Point. When the difference between Room Temperature and Set Point equals the value entered in this parameter, the fan output is increased to the maximum fan level value. Range: 1 ... 100 => 0.1°C ... 10°C
53	Reset Time	R/W	30 min.	0 min.	100 min.	When the time specified in this parameter is exceeded, the fan output value produced by integral-part is equal to the produced by proportional band parameter. (* ) If this value is set to "0", the device operates only according to the proportional band value.
54	Fan Start-Up Time	R/W	3 sec.	0 sec.	30 sec.	To guarantee a safe start-up of the fan, this parameter determines, how long the fan will stay at the fan maximum stage value at the start-up time.
55	Fan Off Delay	R/W	0 sec.	0 sec.	60 sec.	This parameter adjusts delay of the closing time the fan.

56	Alarm	R	0	0	4	This parameter indicates the alarm state. 0 = No alarm 1 = Onboard Sensor Alarm 2 = External Sensor Alarm 3 = Changeover Sensor Alarm 4 = Heater Contact Alarm
57	BMS Icon Enable	R/W	1	0	1	0 = Disable 1 = Enable
58	VA1 status	R	-	0	1	Range: 0 ... 100 => 0V ... 10V
59	VA2 status	R	-	0	1	Range: 0 ... 100 => 0V ... 10V
60	Fan Output Value	R	0	0	100	Range: 0 ... 100 => 0V ... 10V
61	Monday Start Time	R/W	0	0	2359	The hour and minute value written in this parameter are set to turn on the device on Monday.
62	Monday Stop Time	R/W	0	0	2359	The hour and minute value written in this parameter are set to turn off the device on Monday.
63	Tuesday Start Time	R/W	0	0	2359	The hour and minute value written in this parameter are set to turn on the device on Tuesday.
64	Tuesday Stop Time	R/W	0	0	2359	The hour and minute value written in this parameter are set to turn off the device on Tuesday.
65	Wednesday Start Time	R/W	0	0	2359	The hour and minute value written in this parameter are set to turn on the device on Wednesday.
66	Wednesday Stop Time	R/W	0	0	2359	The hour and minute value written in this parameter are set to turn off the device on Wednesday.
67	Thursday Start Time	R/W	0	0	2359	The hour and minute value written in this parameter are set to turn on the device on Thursday.
68	Thursday Stop Time	R/W	0	0	2359	The hour and minute value written in this parameter are set to turn off the device on Thursday.
69	Friday Start Time	R/W	0	0	2359	The hour and minute value written in this parameter are set to turn on the device on Friday.
70	Friday Stop Time	R/W	0	0	2359	The hour and minute value written in this parameter are set to turn off the device on Friday.
71	Saturday Start Time	R/W	0	0	2359	The hour and minute value written in this parameter are set to turn on the device on Saturday.
72	Saturday Stop Time	R/W	0	0	2359	The hour and minute value written in this parameter are set to turn off the device on Saturday.
73	Sunday Start Time	R/W	0	0	2359	The hour and minute value written in this parameter are set to turn on the device on Sunday.
74	Sunday Stop Time	R/W	0	0	2359	The hour and minute value written in this parameter are set to turn off the device on Sunday.

75	Current Year	R/W	2018	2017	2099	This parameter adjusts the current year.
76	Current Month	R/W	-	1	12	This parameter adjusts the current month.
77	Current Day	R/W	-	1	31	This parameter adjusts the current day.
78	Current Hour	R/W	-	00	23	This parameter adjusts the current hour.
79	Current Minute	R/W	-	00	59	This parameter adjusts the current minute.
80	Restore Factory Setting	R/W	0	0	1	0 = Factory Setting Disable 1 = Factory Setting Started
81	Baudrate	R/W	2	1	4	1 = 9600bps      3 = 38400bps 2 = 19200bps    4 = 76800bps
82	Parity	R/W	1	0	2	0 = Odd 1 = Even 2 = None
83	Slave Address	R/W	1	1	247	This parameter shows address of the device.
84	Parameter Menu Password	R/W	203	1	999	This parameter is set to the password to be entered in the parameter menu.
85	6 Way Valve Deadband	R/W	2	0	4	This parameter determines the dead band value for the 6-way valve.
86	Sequence 1 Minimum Value	R/W	40	0	100	This parameter displays the minimum value of sequence 1 valve.
87	Sequence 2 Minimum Value	R/W	60	0	100	This parameter displays the minimum value of sequence 2 valve.

**Dimensions (mm)**

