

**T3065.32**  
**Touch Button EC Proportional Fan Coil Thermostat**



For 2-pipe and 4-pipe Fan Coil Units

**Features**

- Manual or automatic fan control with selectable stages
- Proportional control heating/cooling valves
- 6-Ways Valve Control
- Auto, Heat, Cool and Ventilation modes
- Economy Mode
- Manual or automatic heating/cooling changeover
- Fan Only, Heating and Fan, Cooling and Fan options
- On/off electric heater control
- Universal input for external sensor or windows/energy saving contact etc.
- Automatic heating/cooling changeover via changeover sensor
- Automatic heating/cooling changeover via changeover contact
- Remote On/Off via contact
- User setpoint limitation
- Clock and time schedule functions
- Key lock
- Configurable user parameters
- BACnet MS/TP communication
- Modern styling and capacitive touch buttons
- White backlight LCD
- Different colour options; black and white
- EU box flush-mount



**Applications**

T30x5 Series Fan Coil Thermostats is used in individual rooms or zones in buildings. It is designed for two and four pipe fan coil units. T3065 has one universal input that can be used as an external sensor or open/close contact input, three analog outputs, one relay output and one RS-485 port. It controls the fan coil unit depending on the internal room sensor or external return sensor temperature.

**Notes on Usage**

Please, read this datasheet carefully. T3065 thermostat is designed and manufactured in accordance with latest technological developments and safety. To avoid injury and property damage, safety warnings must be observed.

**Security Advice-Caution**

Assembly, maintenance, and repair must be done by authorized service. The power supply of the device is 24 V AC/DC and it has no internal fuse. External protection with max C 5 A circuit breaker required in all cases. Disconnect from power supply before separating front plate.



**Ordering Information**

Product Code	Description	Power	Communication
T3065.32	1 Analog Output (0-10 V) Fan Control 2 Analog Outputs (0-10 V) Valve Control 1 Digital Output (Relay) Electrical Heater Control 1 Universal Input 1 RS-485 Port	24 V AC/DC	BACnet MS/TP

**Technical Specification**

Power Supply	24 V AC/DC
Power Consumption	Max ~3.0 VA
Electrical Connection	Terminal Connectors
Battery for Real Time Clock (RTC)	Lithium CR1220 3.3V
Measuring Range	-10°C ... +100°C (+14°F ... +212°F)
Resolution	0.1°C (1°F)
Inputs	1 Universal Input (NTC 10K or Dry Contact)
Outputs	3 Analog Outputs (0-10 V), 1 Digital Output (5 (2) A Relay)
Communication	1 x RS-485 Port
Temperature Setting	5°C ... 40°C (Adjustable) (41°F ... 104°F (Adjustable))
Dimensions	86 x 86 x 52 mm
Mounting	Flush Mounted (Standard EU box)

**Mounting Location**

Thermostat is suggested to be installed indoors, a place with around 1.5m height above the floor so that it can measure the average room temperature. It should be away from direct sunlight, any cover or any heat source, to avoid false signals for temperature control.



**CAUTION: Cut off the supply power at the circuit breaker or fuse before installation to avoid fire, shock or death!**

## Mounting Instructions

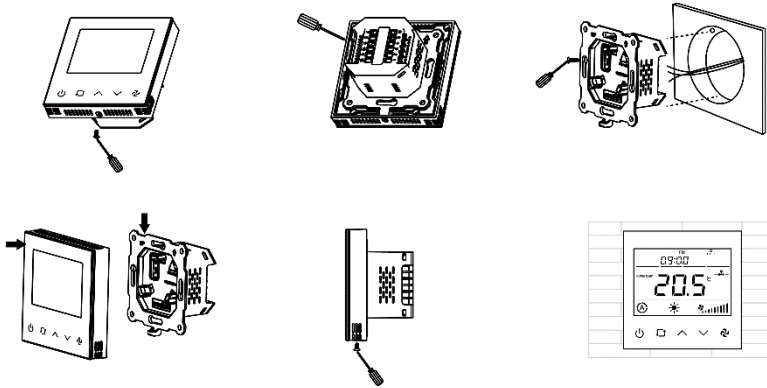

Please follow below instructions during mounting.

**Step 1:** Take the thermostat out from the package. Get the datasheet inside the package.

**Step 2:** Connect the wires properly according to the wiring diagram below.

**Step 3:** Separate the front plate and the back plate, and then use screwdriver to fix the back plate into the electric box with 4 screws.

**Step 4:** Attach the front plate to the back plate, making sure the pin plates on each side are well matched.

**Step 5:** Compare it with the pictures after installation.

**Step 6:** Power on the thermostat to work.

**Important Note 1:** It is recommended to use the following flush mount boxes for better mounting:

Alternative 1: Manufacturer: Viko by Panasonic, Part Number: 90926006 (Depth must be minimum 50 mm!)

Alternative 2: Manufacturer: Legrand, Part Number: 0 801 21 (Depth must be minimum 50 mm!)

**Important Note 2:** It is recommended to use the screws included in the product box. Otherwise, there could be fitting problems during the mounting.

Connection Diagrams

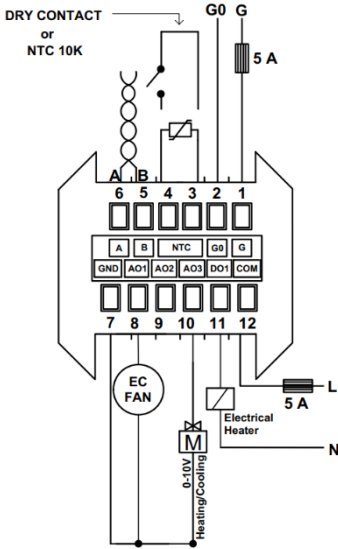

Connection Diagram for 2-Pipe Fan Coil and 6-Way Valve

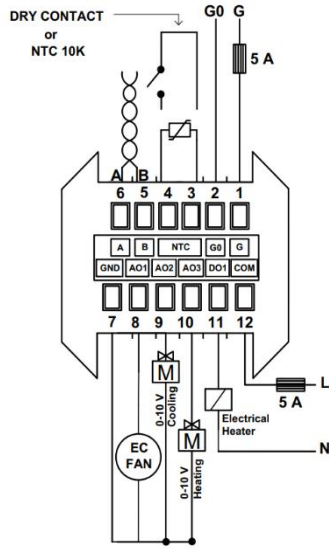

Connection Diagram for 4-Pipe Fan Coil

**Note:** Thermostat has no internal fuse. External protection with max C 5 A circuit breaker required in all cases. Isolate the cables of NTC – dry contact from 24 V power supply.

**Display and Operations**

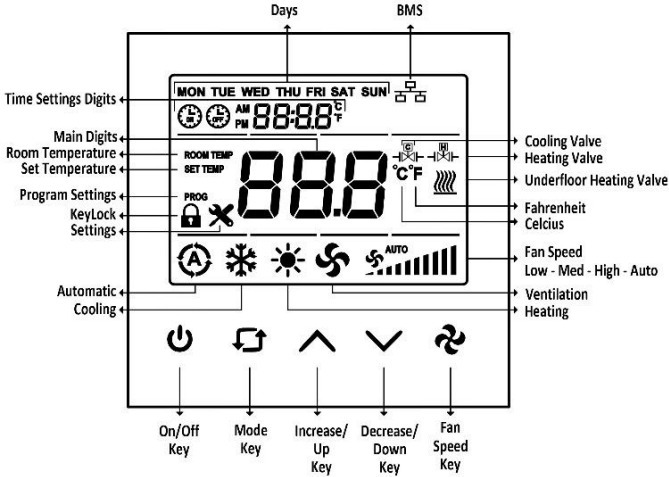

• **Mode Selection:** Press the **MODE** key to change the mode of the device. Active mode options are as follows.

	<b>AUTOMATIC</b>	<b>COOL</b>	<b>HEAT</b>	<b>FAN</b>
<b>FAN ONLY</b>	-	-	-	√
<b>COOLING + FAN</b>	-	√	-	√
<b>2 PIPE SYSTEM</b>	-	√	√	√
<b>HEATING + FAN</b>	-	-	√	√
<b>4 PIPE SYSTEM</b>	√	√	√	√
<b>6 WAY VALVE SYSTEM</b>	√	√	√	√

• **Fan Selection:** When the **FAN SPEED** key is pressed, fan speed can be changed as Stage 1, Stage 2, Stage 3, Stage 4, Stage 5, Auto. The fan can be selected as 1 stage, 3 stage or 5 stage via parameter P44.

• **Time Settings:** After pressing the **MODE** key for 3 seconds, year digits flashes on the panel. **MODE** key is pressing once again, month digit flashes on the panel. **MODE** key is pressed once again, day digit flashes on the panel. **MODE** key is pressed once again, hour digit flashes on the panel. **MODE** key is pressed once again, minute digit flashes on the panel. **MODE** key is pressed once again, day of week digit flashes on the panel. Year, month, day, hour, minute, day of week information are be changed by **INCREASE** and **DECREASE** keys.

**Order:** Year -> Month -> Day -> Hour -> Minute -> Day Of Week

• **Schedule Operations:** Be sure to set the time settings, before making schedule operations. After setting the day, to enter the Schedule menu, press the **MODE** key one time. While in the Schedule menu, "**Monday opening time hour digit**" flashes on the panel. When the **MODE** key is pressed once again, "**Monday opening time minute digit**" flashes on the panel. Then, when the **MODE** key is pressed one more time, "**Monday closing time hour digit**" flashes on the panel. After that when the **MODE** key is pressed once again, "**Monday closing time minute digit**" flashes on the panel. While the digits flashing, hour and minute can be changed by **INCREASE** and **DECREASE** keys. Use the **MODE** key to set the other days' schedule.

**Note:** When the time schedule is set, the on/off lock will be activated.

- **Key Lock Operations:** Pressing both **MODE** and **INCREASE** keys, key lock digit displays on the panel. The panel is locked. When the panel is locked, press the **MODE** and **INCREASE** keys to unlock panel. "Key Lock" options can be changed via parameter P6. To lock two or more keys at the same time; sum the numbers of the keys. To lock mode key and on/off key, 1 (on/off) and 2 (mode) should be added and written 3 to parameter P6. To lock setpoint and fan speed, 4 (setpoint) and 8 (fan speed) should be added and written 12 to parameter P6.

## Configuration

### Configuration Menu Description

When the device is on or off position, press together **Main Parameter Increase Key** and **Value Decrease Key** for 3 seconds, to enter the Configuration Menu. In the password screen, Password digits can be changed by **Main Parameter Increase Key**, Password value can be changed by **Value Increase Key** and **Value Decrease Key**. Password must be entered as "203" and **Main Parameter Decrease Key** must be pressed to confirm. When the correct password is written, the configuration menu will be entered. If the wrong password is entered, it will fail, and the password will reset. Password screen will return to main screen without an action 10 seconds. Parameter setting screen will return to main screen without any action in 30 seconds. All parameters are stored within device memory ensuring no data loss if the Thermostat is powered off.

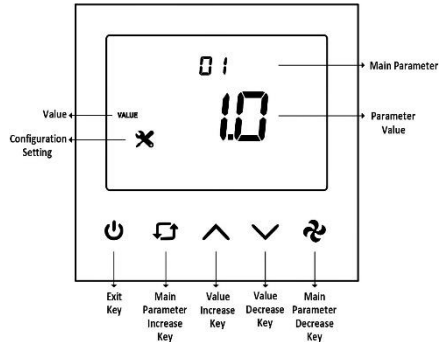

### Energy Saving Mode (ECO Mode) (Parameter P19 or via BACnet)

Economy mode is activated from the authorization point (P19). When economy mode authorization is activated, the device will operate in economy mode instead of OFF state. In ECO mode, the system will operate according to the set point value for heating and cooling.

The situations that will be affected by the economy mode are as follows;

- Auto mode authorization will be turned off.
- Fan/Valve control will operate as Valve Dependent.

NOTE: Economy mode will not be activated when Universal Input is selected Changeover.

### Temperature Input Selection Parameter (Parameter P26 or via BACnet)

- Internal Room Temperature Sensor (parameter P26 = 0)

The system takes the Internal Temperature Sensor as reference. If Universal Input is selected as "1", the system takes the Universal input as reference.

-BMS Room Temperature and Internal Room Temperature Sensor (parameter P26 = 1)

The system takes the value entered from the BMS as reference. If the BMS communication is lost and does not return within five minutes, the system gives an alarm but continues to operate according to the Internal Temperature sensor. If the BMS communication returns, system takes the BMS value as a reference and continues to work.

-BMS Room Temperature (parameter P26 = 2)

The system takes the value entered from the BMS as reference. If the BMS communication is lost, the system gives an alarm and turns off all outputs. It continues to work in the case of communication.

**6-Way Valve (Parameter P32 or via BACnet)**

6-way valve operation diagram is as follows;

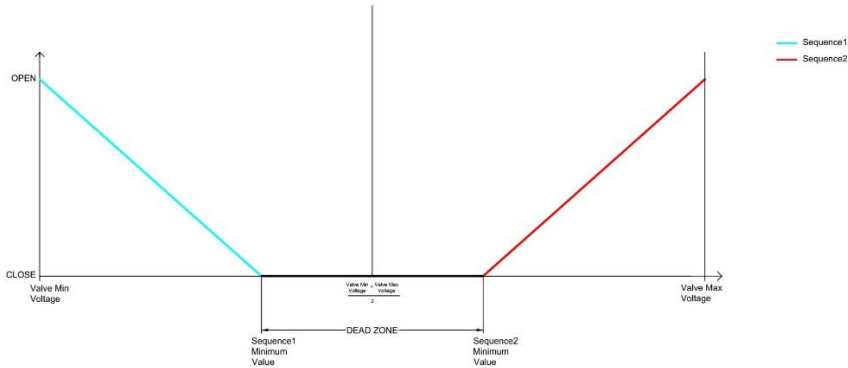

Sequence 1 is set as the default cooling valve. For Sequence 1 to operate in heating mode, it can be done by changing the Valve1 direction parameter.

The dead band mentioned in the graph is the 6-way valve dead zone parameter. (P 25)

\*Dead band is divided equally in Sequence 1 and Sequence 2 plots.

e.g. The midpoint on a 0-10 valve is 5 volts. If the 6-way valve dead band parameter is 2, the minimum value of sequence 1 is  $5 - (2/2) = 4$ . Sequence 2 minimum value is also  $5 + (2/2) = 6$ .

**Universal Input (Parameter P34 or via BACnet)**

- External Sensor for room (parameter P34 = 1)

The device operates according to external temperature sensor value read from universal input.

- External Sensor (parameter P34 = 2)

The device operates according to internal temperature sensor value. The temperature read from the universal input can be monitored from P38 and related BMS point.

- Changeover Sensor (parameter P34 = 3)

If "Universal Input" value is selected as changeover, "dead zone" cannot be used.

Changeover sensor only valid when "Fan Coil Type" is set to 2.

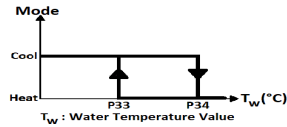

When the water temperature is above P35 the thermostat changes over to heating mode. It stays in heating mode until the temperature falls below P36. When the water temperature is below P35, the thermostat changes over to cooling mode. It stays in cooling mode until the temperature rises above P36.

- Changeover contact-On/Off (NC Contact) (parameter P34 = 4)

Changeover sensor only valid when "Fan Coil Type" is set to 2.

When this contact is closed, the device will operate according to the cooling mode. When the contact is opened, it will operate according to the heating mode.

- Changeover contact-Off/On (NO Contact) (parameter P34 = 5)

Changeover sensor only valid when "Fan Coil Type" is set to 2.

When this contact is opened, the device will operate according to the cooling mode. When the contact is closed, it will operate according to the heating mode.

- Windows contact/Energy saving-On/Off (NC Contact) (parameter P34 = 6)

When this contact is closed, the device is in the "ON" position. When this condition is not met, the device shows "OPEN" on the panel and the outputs of the device are passive.

- Windows contact/Energy saving-Off/On (NO Contact) (parameter P34 = 7)

When this contact is opened, the device is in the "ON" position. When this condition is not met, the device shows "OPEN" on the panel and the outputs of the device are passive.

- Remote Control (NC Contact) (parameter P34=8)

When this contact is open, the device is in the "Off-ECO" position. When the contact is turned off, the device will switch to the "On" position. In this case, On/Off key will be locked, it will not be able to be written via BACnet and the Time Schedule will be disabled.

- Remote Control (NO Contact) (parameter P34=9)

When this contact is closed, the device is in the "Off-ECO" position. When the contact is turned on, the device will switch to the "On" position. In this case, On/Off key will be locked, it will not be able to be written via BACnet and the Time Schedule will be disabled.

- Remote Off-ECO (NC Contact) (parameter P34=10)

When this contact is open, the device is in the "Off-ECO" position. If the contact is closed, the device will continue to operate in its previous position. When the device is in the "Off" position, On/Off key will be locked, it will not be able to be written via BACnet and the Time Schedule will be disabled.

- Remote Off-ECO (NO Contact) (parameter P34=11)

When this contact is closed, the device is in the "Off-ECO" position. If the contact is open, the device will continue to operate in its previous position. When the device is in the "Off" position, On/Off key will be locked, it will not be able to be written via BACnet and the Time Schedule will be disabled.

- Heater Contact (NC Contact) (parameter P34 = 12)

When this contact is opened, the electrical heater output is closed. The device shows "AL 04" on the panel.

- Heater Contact (NO Contact) (parameter P34 = 13)

When this contact is closed, the electrical heater output is closed. The device shows "AL 04" on the panel.

### Hysteresis (Parameter P42 or via BACnet)

The output diagram of the valve according to the relation between  $T_S$  and  $T_R$  is given below.

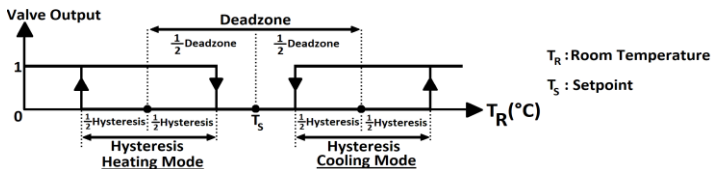

### Fan/Valve Control Selection (Parameter P43 or via BACnet)

In valve independent mode, the fan operates according to manual fan selection or automatic fan control. When valve is closed, the fan will continue to operate.

In valve dependent mode, the fan will be closed when the valve is closed. If the valve is open, the fan will operate according to manual fan selection or automatic fan control.



### Fan Stage Selection (Parameter P44 or via BACnet)

The thermostat fan speed can be adjusted as 1, 3 or 5 stage via P44 or via BACnet. The minimum and maximum fan speed output values can be adjusted via P45 and P46, respectively.

### Fan Output Value Calculation (via BACnet)

Fan output value is calculated as below;

Fan Output Value in Fan Stage X = Fan Minimum Stage Value + Value \* Fan Stage X

Value is calculated below;

Value = (Fan Maximum Stage Value – Fan Minimum Stage Value) / Fan Stage Selection

For Example;

Fan Minimum Stage Value (Parameter P45 or via BACnet) = 20

Fan Maximum Stage Value (Parameter P46 or via BACnet) = 80

Fan Stage Selection (Parameter P42 or via BACnet) = 3

Value = (80 - 20) / 3 = 20

Fan Output Value in Fan Stage 1 = 20 + 20 \* 1 = 40

Fan Output Value in Fan Stage 2 = 20 + 20 \* 2 = 60

Fan Output Value in Fan Stage 3 = 20 + 20 \* 3 = 80

### Restore Factory Setting (Parameter P52 or via BACnet)

The device can load the factory setting parameters via parameter P52, by changing the value to “1”, and pressing button **Exit** Key. While in the factory reset process, lines on the top and the bottom will be running from left to right for 3 seconds. The display shows top and bottom lines loaded step by step during reload process approximately 3 seconds.

### Alarms

Alarm Code will appear on the screen, during alarm. if one of the alarm conditions is met. Alarm Codes will appear on the screen alternately. If more than one alarm condition is met.

- Onboard Sensor Alarm:

If the internal temperature sensor fails, “**AL 01**” will appear on the screen and “Err” will be shown on the main digits. During the alarm, device outputs will be closed. If the “Universal Input” is selected to “External Sensor”, the device continues normal operation.

- External Sensor Alarm:

If the “Universal Input” parameter is set to “External Temperature Sensor” and sensor is not connected or connection breaks down, “**AL 02**” will appear on the screen and “Err” will be shown on the main digits. During the alarm, device outputs will be closed. “Universal Input” is set to “Not Used” to eliminate the alarm.

- Changeover Sensor Alarm:

If the “Universal Input” is selected to “Changeover Sensor” also the sensor is broken down, displayed “**AL 03**” on the panel and “Err” on the Main Digits. During the alarm, device outputs will be closed. “Universal Input” is set to “Not Used” to eliminate the alarm.

- Heater Contact Alarm

If the “Universal Input” is selected to “Heater Contact (NO-NC)” also the contact is broken down, displayed (if NO is selected the connection is short circuit) “**AL 04**” on the panel. During the alarm, device heater output will be closed.

-BMS Temperature Input Alarm:

If the “Temperature Input Selection” parameter is selected as “1”, BMS communication gets lost and if it does not return within 5 minutes, “**AL 05**” alarm will be displayed on the screen. The system will take the Internal Temperature

Sensor value as the reference temperature. When the BMS communication is returned, the BMS temperature value will be referenced again, and the alarm will disappear.

If BMS communication is lost when "Temperature Input Selection" parameter is "2", "AL 05" alarm and "Err" in Main Digits will be displayed on the screen. The device turns off its outputs in case of alarm. To eliminate the alarm, BMS communication must be made, or "Temperature Input Selection" parameter must be selected as "0".

### Configuration Menu Parameters

No.	Name of Parameter	Parameter Definition	Default
P1	Hardware Version	Device hardware version	2.1
P2	Firmware Version	Device firmware version	1.6
P3	Setpoint High Limit	Range: Set Point Low Limit ... 99.9°C (Range: 41°F ... 212°F)	30°C (86°F)
P4	Setpoint Low Limit	Range: 5°C ... Set Point High Limit (Range: 41°F ... 86°F)	5°C (41°F)
P5	Main Screen	0 = Room temperature 1 = Setpoint temperature 2 = Room Temperature and Setpoint Temperature alternate	0
P6	Key Lock	0 = Unlocked 1 = Lock On/Off 2 = Lock Mode 4 = Lock Setpoint 8 = Lock Fan Speed 16 = Lock Time Settings 32 = Lock Time Schedule Settings 63 = Locked All (* ) To lock two or more keys at the same time; sum the numbers of the keys. To lock setpoint and fan speed, 4 (Setpoint) and 8 (Fan Speed) should be added and written 12.	0
P7	Celsius or Fahrenheit	0 = Celsius 1 = Fahrenheit	0
P8	Time Format	0 = 24 hours clock 1 = 12 hours clock (AM/PM) (* ) The system Time Format is 24 hours clock. This parameter adjusts how to clock format on the panel/screen will shown.	1
P9	Time Schedule Enable	0 = Disable 1 = Enable	0
P10	Screen Saver	0 = Screen Saver Disabled 1 = Display On 2 = Display Off 3 = Main Screen Temperature 4 = Main Screen and Clock 5 = Room Temperature and Setpoint alternately, and Clock (* )When the Main Screen parameter is set to "2", Room Temperature appears instead of Main Screen at the 3. and 4. parameters	4
P11	Screen Saver Mode Delay	Range: 10 ... 150 seconds	60 sec.
P12	LCD Brightness	Range: 1 ... 5 stages	5
P13	Buzzer Stage	Range: 0 ... 5 stages	3
P14	Power Failure	This parameter adjusts the condition that the device will continue when the power failure happens. 0 = Device starts off 1 = Device starts on 2 = Keep State Before Power Failure	2

<b>P15</b>	Screen Off State Status	0: Screen off 1: Room Temperature 2: Room Temperature and Off 3: Room Temperature and Clock	1
<b>P16</b>	Valve Proportional Band	Range: 1 ... 100 => 0.1°C ... 10°C	20
<b>P17</b>	Electrical Heater Enable	0 = Disable 1 = Enable	0
<b>P18</b>	Electrical Heater Setpoint Differential	Range: 0 ... 150 => 0°C ... 15°C	50
<b>P19</b>	ECO Mode Activation	0 = Eco Mode authorization turned off 1 = Eco Mode authorization turned on	0
<b>P20</b>	ECO Mode Cooling Mode Set Point	Set Point Low Limit ... Set Point High Limit	21°C (69,8°F)
<b>P21</b>	ECO Mode Heating Mode Set Point	Set Point Low Limit ... Set Point High Limit	21°C (69,8°F)
<b>P22</b> : <b>P24</b>	Reserved	-	-
<b>P25</b>	6 Way Valve Deadband	This parameter determines the deadband value for the 6-way valve.	2
<b>P26</b>	Temperature Input Selection	This parameter determines which input the room temperature will operate according to. 0 = Internal Temperature Sensor/Universal Input 1 = BMS/Internal Temperature Sensor 2 = BMS	0
<b>P27</b>	Valve Minimum Value	It determines the minimum value of the valve outputs. 0 ... 100 => 0V ... 10V	0
<b>P28</b>	Valve Maximum Value	It determines the maximum value of the valve outputs. 0 ... 100 => 0V ... 10V	100
<b>P29</b>	Underfloor Heating Activation	0 = Underfloor heating disable 1 = Underfloor heating enable	0
<b>P30</b>	VA1 Direction	0 = Normal Direct 1 = Reverse Direct	0
<b>P31</b>	VA2 Direction	0 = Normal Direct 1 = Reverse Direct	0
<b>P32</b>	Fan Coil Type	0 = Fan Only 1 = 2 pipe system Cooling + Fan 2 = 2 pipe system 3 = 2 pipe system Heating + Fan 4 = 4 pipe system 6 = 6-Ways valve system	4
<b>P33</b>	Internal Temperature Sensor Calibration	Range: -10°C ... 10°C and 0.1°C steps (Range: -18°F ... 18°F and 1°F steps)	0°C (0°F)

P34	Universal Input	<p>0 = Not used            1 = External Temperature sensor for room (NTC 10K)            2 = External Temperature sensor (NTC 10K) (Monitoring purpose)            3 = Changeover sensor (NTC 10K)            4 = Changeover contact-On/Off (NC Contact)            5 = Changeover contact-Off/On (NO Contact)            6 = Windows contact/Energy saving-On/Off (NC Contact)            7 = Windows contact/Energy saving-Off/On (NO Contact)            8 = Remote Control (NC Contact)            9 = Remote Control (NO Contact)            10 = Remote Off (NC Contact)            11 = Remote Off (NO Contact)            12 = Heater Contact (NC Contact)            13= Heater Contact (NO Contact)</p>	0
P35	Changeover Temperature For Cooling	Range: 10°C ... 25°C. Only valid when P32 is set to 3 (Range: 50°F ... 77°F. Only valid when P32 is set to 3)	16°C (60°F)
P36	Changeover Temperature For Heating	Range: 26°C ... 45°C. Only valid when P32 is set to 3 (Range: 78°F ... 113°F. Only valid when P32 is set to 3)	28°C (82°F)
P37	Mode Change Delay	Range: 0 ... 255 minutes	3 min.
P38	Universal Input Temperature	If P32 is "1", "2" or "3", this parameter shows the sensor temperature.	0°C (0°F)
P39	Universal Input Temperature Calibration	Range: -10°C ... 10°C and 0.1°C steps (Range: -18°F ... 18°F and 1°F steps)	0°C (0°F)
P40	Auto Mode Enable	0 = Disable 1 = Enable Only valid when P32 is set to 4	1
P41	Dead Zone	Range: 0°C ... 15°C. Only valid when P38 is set to 1 (Range: 0°F ... 27°F. Only valid when P38 is set to 1)	2°C (3°F)
P42	Hysteresis	Range: 0°C ... 15°C (Range: 0°F ... 27°F)	1°C (1°F)
P43	Fan/Valve Control Selection	0 = Valve independent 1 = Valve dependent	1
P44	Fan Stage Selection	1 = 1 Stage 3 = 3 Stage 5 = 5 Stage	5
P45	Fan Minimum Stage Value	Range: 0 ... 100 => 0V ... 10V	0
P46	Fan Maximum Stage Value	Range: 0 ... 100 => 0V ... 10V	100
P47	Fan Proportional Band	Range: 1 ... 100 => 0.1°C ... 10°C	20
P48	Reset Time	Range: 0 ... 100 minutes	30 min.
P49	Fan Start-Up Time	Range: 0 ... 30 seconds	3 sec.
P50	Fan Off Delay	Range: 0 ... 60 seconds	0 sec.
P51	BMS Icon Enable	0 = Disable 1 = Enable	1
P52	Restore Factory Setting	0 = Factory Setting Disable 1 = Factory Setting Started	0
P53	Baudrate	1 = 9600bps 2 = 19200bps 3 = 38400bps 4 = 76800bps	4
P54	Loop ID	Range: 00 ... 04	0
P55	MAC Address	Range: 001 ... 127	1
P56	Parameter Menu Password	Range: 001 ... 999 (Read Only)	203

**BACnet Parameters**

According to BACnet standards, MSTP port configurations are as follows;

-8 Data Bits, None Parity, 1 Stop Bit

**MAC Address:** 1 ... 127. **Default 1**

**Baudrate** : 9600, 19200, 38400, 76800. **Default 76800**

**Note 1:** The MAC address can be changed via configuration menu.

**Note 2:** Device Instance Number (Device ID) is automatically calculated as below;

Device ID = 856 \* 1000 + Loop ID \* 200+ MAC

For example: Mac: 13, Loop ID: 1 => Device ID = 856 \* 1000 + 1 \* 200+ 13 = 856213

When the MAC address is changed via configuration menu, the Device ID is automatically recalculated to avoid network ID conflict.

As a property of Device Object, Device ID value is writable via BACnet between 0 and 4194302. Once the Device ID is changed via BACnet, Device ID automatic calculation mentioned above is ineffective.

**End of Line (EOL) Resistor**

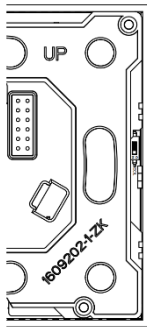

When the thermostat front plate is flipped, the EOL resistor DIP switch is seen on the upper right side of the back plate. This resistor's default position is OFF. When the End of Line (EOL) resistor is needed to be used, DIP Switch position should be switched to ON.

**OFF Position**



**ON Position**



**T3065.32 BACnet Object List**

N <sup>o</sup>	Object	Value	Object Name	Function	Default	Read (R)/Write (W)
----------------	--------	-------	-------------	----------	---------	--------------------

**Analog Inputs**

1	Analog Input #1	-9.9°C ... 99.9°C (14.1°F ... 211.8°F)	Room Temperature	This parameter shows the room temperature value.	-	R
2	Analog Input #2	-9.9°C ... 99.9°C (14.1°F ... 211.8°F)	Universal Input Temperature	If "Universal Input" is "1", "2" or "3", this parameter shows the sensor temperature.	-	R
3	Analog Input #3	0 ... 10	Sequence 1 Minimum Value	This parameter displays the minimum value of sequence 1 valve.	4	O
4	Analog Input #4	0 ... 10	Sequence 2 Minimum Value	This parameter displays the minimum value of sequence 2 valve.	6	O

**Analog Values**

5	Analog Value #1	0 ... 3	Mode	0 = Fan Only 1 = Heat 2 = Cool 3 = Auto	3	R/W
6	Analog Value #2	1 ... 6	Fan Speed	1 = Stage 1 2 = Stage 2 3 = Stage 3 4 = Stage 4 5 = Stage 5 6 = Auto	1	R/W
7	Analog Value #3	Set Point Low Limit ... Set Point High Limit	Set Point	This parameter is the desired room temperature value.	21°C (69.8°F)	R/W
8	Analog Value #4	Set Point Low Limit ... 99.9°C (41°F ... 212°F)	Set Point High Limit	This parameter adjusts the high limit for desired room temperature.	30°C (86°F)	R/W
9	Analog Value #5	5°C ... Set Point High Limit (41°F ... 86°F)	Set Point Low Limit	This parameter adjusts the low limit for desired room temperature.	5°C (41°F)	R/W
10	Analog Value #6	0 ... 63	Key Lock	0 = Unlocked 1 = Lock On/Off 2 = Lock Mode 4 = Lock Setpoint 8 = Lock Fan Speed 16 = Lock Time Settings 32 = Lock Time Schedule Settings 63 = Locked All (* ) To lock two or more keys at the same time; sum the numbers of the keys. To lock setpoint and fan speed, 4 (Setpoint) and 8 (Fan Speed) should be added and written 12.	0	R/W
11	Analog Value #7	0 ... 2	Power Failure	This parameter adjusts the condition that the device will continue when the power failure happens. 0 = Device starts off 1 = Device starts on 2 = Keep State Before Power Failure	2	R/W
12	Analog Value #8	0 ... 4	Fan Coil Type	0 = Fan Only 1 = 2 pipe system Cooling + Fan 2 = 2 pipe system 3 = 2 pipe system Heating + Fan 4 = 4 pipe system 6 = 6-Ways valve sytem	4	R/W

13	Analog Value #9	-10°C ... 10°C (-18°F ... 18°F)	Internal Temperature Sensor Calibration		0°C (0°F)	R/W
14	Analog Value #10	0 ... 13	Universal Input	<p>0 = Not used</p> <p>1 = External Temperature sensor for room (NTC 10K)</p> <p>2 = External Temperature sensor (NTC 10K) (Monitoring purpose)</p> <p>3 = Changeover sensor (NTC 10K)</p> <p>4 = Changeover contact- On/Off (NC Contact)</p> <p>5 = Changeover contact- Off/On (NO Contact)</p> <p>6 = Windows contact/Energy saving-On/Off (NC Contact)</p> <p>7 = Windows contact/Energy saving-Off/On (NO Contact)</p> <p>8 = Remote Control (NC Contact)</p> <p>9 = Remote Control (NO Contact)</p> <p>10 = Remote Off (NC Contact)</p> <p>11 = Remote Off (NO Contact)</p> <p>12 = Heater Contact (NC Contact)</p> <p>13 = Heater Contact (NO Contact)</p>	0	R/W
15	Analog Value #11	10°C ... 25°C (50°F ... 77°F)	Changeover Temperature for Cooling	If "Universal Input" is set to "3", this parameter adjusts changeover temperature for cooling mode.	16°C (60.8°F)	R/W
16	Analog Value #12	26°C ... 45°C (78.8°F ... 113°F)	Changeover Temperature for Heating	If "Universal Input" is set to "3", this parameter adjusts changeover temperature for heating mode.	28°C (82.4°F)	R/W
17	Analog Value #13	0 min. ... 255 min.	Mode Change Delay	This parameter adjusts delay time between heat and cool modes.	3 min.	R/W
18	Analog Value #14	-10°C ... 10°C (-18°F ... 18°F)	Universal Input Temperature Calibration		0°C (0°F)	R/W
19	Analog Value #15	0°C ... 15°C (0°F ... 27°F)	Dead Zone	If "Mode" is set to "Auto", this parameter adjusts dead zone.	2°C (3.6°F)	R/W
20	Analog Value #16	0°C ... 15°C (0°F ... 27°F)	Hysteresis	This parameter adjusts hysteresis.	1°C (1.8°F)	R/W
21	Analog Value #17	1 ... 5	Fan Stage Selection	<p>1 = 1 Stage</p> <p>3 = 3 Stage</p> <p>5 = 5 Stage</p>	5	R/W
22	Analog Value #18	0 ... 100	Fan Minimum Stage Value	Range : 0V ... 10V => (0 ..100)	0	R/W

23	Analog Value #19	0 ... 100	Fan Maximum Stage Value	Range : 0V ... 10V => (0 ..100)	100	R/W
24	Analog Value #20	1 ... 100 ( 0.1°C ... 10°C)	Fan Proportional Band	This parameter determines proportionally the output value of the fan depending on the difference between Room Temperature and Set Point. When the difference between Room Temperature and Set Point equals the value entered in this parameter, the fan output is increased to the maximum fan level value.	20	R/W
25	Analog Value #21	0 min. ... 100 min.	Reset Time	When the time specified in this parameter is exceed, the fan output value produced by integral-part is equal to the produced by proportional band parameter. (* ) If this value is set to "0", the device operates only according to the proportional band value.	30 min.	R/W
26	Analog Value #22	0 sec. ... 60 sec.	Fan Off Delay	This parameter adjusts delay of the closing time the fan.	0 sec.	R/W
27	Analog Value #23	0 ... 100	Fan Output Value	Range : 0V ... 10V => (0 ..100)	0	R
28	Analog Value #24	1 ... 100	Valve Proportional Band	This parameter determines proportionally the output value of the fan depending on the difference between Room Temperature and Set Point. Range: 0.1°C ... 10°C	20	R/W
29	Analog Value #25	1 ... 100	VA1	0 = Close 100 = 10 V	0	R
30	Analog Value #26	1 ... 100	VA2	0 = Close 100 = 10 V	0	R
31	Analog Value #27	0 ... 15	Electric Heater Opening Difference	This parameter determines the difference between the desired temperature and the room temperature for switching on the electrical heater. Range: 0°C ... 15°C	5	R/W



32	Analog Value #28	0 ... 4	Alarm	This parameter indicates the alarm state. 0 = No alarm 1 = Onboard Sensor Alarm 2 = External Sensor Alarm 3 = Changeover Sensor Alarm 4 = Electrical Heater Contact Alarm	0	R
33	Analog Value #29	0...2359	Monday Start Time	The hour and minute value written in this parameter are set to turn on the device on Monday.	0	R/W
34	Analog Value #30	0...2359	Monday Stop Time	The hour and minute value written in this parameter are set to turn off the device on Monday.	0	R/W
35	Analog Value #31	0...2359	Tuesday Start Time	The hour and minute value written in this parameter are set to turn on the device on Tuesday.	0	R/W
36	Analog Value #32	0...2359	Tuesday Stop Time	The hour and minute value written in this parameter are set to turn off the device on Tuesday.	0	R/W
37	Analog Value #33	0...2359	Wednesday Start Time	The hour and minute value written in this parameter are set to turn on the device on Wednesday.	0	R/W
38	Analog Value #34	0...2359	Wednesday Stop Time	The hour and minute value written in this parameter are set to turn off the device on Wednesday.	0	R/W
39	Analog Value #35	0...2359	Thursday Start Time	The hour and minute value written in this parameter are set to turn on the device on Thursday.	0	R/W
40	Analog Value #36	0...2359	Thursday Stop Time	The hour and minute value written in this parameter are set to turn off the device on Thursday.	0	R/W
41	Analog Value #37	0...2359	Friday Start Time	The hour and minute value written in this parameter are set to turn on the device on Friday.	0	R/W
42	Analog Value #38	0...2359	Friday Stop Time	The hour and minute value written in this parameter are set to turn off the device on Friday.	0	R/W
43	Analog Value #39	0...2359	Saturday Start Time	The hour and minute value written in this parameter are set to turn on the device on Saturday.	0	R/W

44	Analog Value #40	0...2359	Saturday Stop Time	The hour and minute value written in this parameter are set to turn off the device on Saturday.	0	R/W
45	Analog Value #41	0...2359	Sunday Start Time	The hour and minute value written in this parameter are set to turn on the device on Sunday.	0	R/W
46	Analog Value #42	0...2359	Sunday Stop Time	The hour and minute value written in this parameter are set to turn off the device on Sunday.	0	R/W
47	Analog Value #43	2017 ... 2099	Current Year	This parameter adjusts the current year.	2023	R/W
48	Analog Value #44	1 ... 12	Current Month	This parameter adjusts the current month.	-	R/W
49	Analog Value #45	1 ... 31	Current Day	This parameter adjusts the current day.	-	R/W
50	Analog Value #46	00 ... 23	Current Hour	This parameter adjusts the current hour.	-	R/W
51	Analog Value #47	00 ... 59	Current Minute	This parameter adjusts the current minute.	-	R/W
52	Analog Value #48	1 ... 4	Baudrate	1 = 9600bps 2 = 19200bps 3 = 38400bps 4 = 76800bps	4	R/W
53	Analog Value #49	1 ... 999	Parameter Menu Password	This parameter is set to the password to be entered in the parameter menu.	203	R/W
54	Analog Value #50	0 ... 100	Valve Minimum Value	It determines the minimum value of the valve outputs. 0 ... 100 => 0V ... 10V	0	R/W
55	Analog Value #51	0 ... 100	Valve Maximum Value	It determines the maximum value of the valve outputs. 0 ... 100 => 0V ... 10V	100	R/W
56	Analog Value #47	5°C ... 99,9°C (41°F ... 212°F)	BMS Room Temperature	It is the Room Temperature value entered via BMS.	22,5°C (72,5°F)	R/W
57	Analog Value #48	Set Point Low Limit Set Point High Limit	Eco Mode Cooling Set Point	This parameter is the Set Point value for ECO MODE Cooling Mode.	21°C (69,8°F)	R/W
58	Analog Value #49	Set Point Low Limit Set Point High Limit	Eco Mode Heating Set Point	This parameter is the Set Point value for ECO MODE Heating Mode.	21°C (69,8°F)	R/W
59	Analog Value #50	0 ... 2	Temperature Input Selection	0=Panel/Universal Input 1=BMS/Panel 2=BMS	0	R/W
60	Analog Value #51	0 ... 4	6 Way Valve Deadband	This parameter determines the dead band value for the 6-way valve.	2	R/W

**Binary Inputs**

61	Binary Input #1	0 ... 1	Universal Input Digital Input Value	0 = Off 1 = On	-	R
----	-----------------	---------	-------------------------------------	-------------------	---	---

**Binary Values**

62	Binary Value #1	0 ... 1	Start/Stop	0 = Stop 1 = Start	1	R/W
63	Binary Value #2	0 ... 1	Celsius or Fahrenheit	0 = Celsius 1 = Fahrenheit	0	R/W
64	Binary Value #3	0 ... 1	Auto Mode Enable	0 = Disable 1 = Enable	1	R/W
65	Binary Value #4	0 ... 1	Fan/Valve Control Selection	0 = Valve Independent 1 = Valve Dependent	1	R/W
66	Binary Value #5	0 ... 1	Electric Heater Status	0 = Electrical Heater Closed 1 = Electrical Heater Opened	0	R
67	Binary Value #6	0 ... 1	Restore Factory Setting	0 = Factory Setting Disable 1 = Factory Setting Started	0	R/W
68	Binary Value #7	0 ... 1	Time Schedule Local and Remote Selection	0 = Time Schedule Local 1 = Time Schedule Remote	0	R/W
69	Binary Value #8	0...1	VA1 Direction	0 = Normal Direct 1 = Reverse Direct	0	R/W
70	Binary Value #9	0...1	VA2 Direction	0 = Normal Direct 1 = Reverse Direct	0	R/W
71	Binary Value #10	0...1	Underfloor Heating Activation	0 = Underfloor Heating Disable 1 = Underfloor Heating Enable	0	R/W
72	Binary Value #10	0...1	Eco Mode Enable	0 = Economy Mode authorization disabled 1 = Economy Mode authorization enabled	0	R/W

**Dimensions (mm)**

